

# FlightStrata™ 100 XA



## Installation and Maintenance



# Copyrights and Disclaimer

© 2005, LightPointe. All Rights Reserved

Information in this document is provided in connection with LightPointe products. These materials are provided by LightPointe as a service to its customers and may be used for information purposes only. LightPointe assumes no responsibility for errors or omissions in these materials. LightPointe may make changes to specifications and product descriptions at any time, without notice. LightPointe makes no commitment to update the information and shall have no responsibility whatsoever for conflicts or incompatibilities arising from future changes to its specifications and product descriptions.

No license, express or implied, by estoppel or otherwise, to any intellectual property rights is granted by this document. Except as provided in LightPointe Terms and Conditions of Sale for such products, LightPointe assumes no liability whatsoever.

These materials are provided "as is" without warranty of any kind, either expressed or implied, relating to sale and/or use of LightPointe products including liability or warranties relating to fitness for a particular purpose, consequential or incidental damages, merchantability, or infringement of any patent copyright or other intellectual property right. LightPointe further does not warrant the accuracy or completeness of the information, text, graphics or other items contained within these materials. LightPointe shall not be liable for any special, indirect, incidental, or consequential damages, including without limitation, lost revenues or lost profits, which may result from the use of these materials.

LightPointe products are not intended for use in medical, lifesaving or life sustaining applications. LightPointe customers using or selling LightPointe products for use in such applications do so at their own risk and agree to fully indemnify LightPointe for any damages resulting from such improper use or sale.

The following are trademarks of LightPointe Product names or services listed in this publication are for identification purposes only, and may be trademarks of third parties. Third-party brands and names are the property of their respective owners.

FlightLite™, FlightPath™, FlightStream™, FlightStrata™, FlightPower™, FlightManager™ and FSO™ are trademarks of LightPointe.

LightPointe believes the printed matter contained herein to be accurate from date of publication and reserves the right to make changes as necessary without notice

**Reader Response:** LightPointe strives to produce quality documentation and welcomes your feedback. Please send comments and suggestions to LightPointe. For technical questions, contact your local LightPointe sales office or field applications engineer.

# Table of Contents

<b>1. SYSTEM OVERVIEW .....</b>	<b>1-1</b>
1.1. System Introduction .....	1-1
1.1.1. DualPath™ Architecture.....	1-1
Free-Space Optical Transmission (Primary Link) .....	1-1
Radio Frequency (Secondary Link) .....	1-2
Switching .....	1-2
Configuration and Management .....	1-2
1.1.2. Typical Applications .....	1-3
1.1.3. Network Interface Connectivity .....	1-3
1.2. System Components.....	1-3
1.2.1. Optical Components.....	1-3
Optical System Block Diagram.....	1-4
Transmission Components .....	1-4
Receiver Components.....	1-5
Multi-Beam Array Tracking and Automatic Gain Control .....	1-5
Lens Geometry.....	1-5
1.2.2. RF Components.....	1-6
1.2.3. XA Switch Components .....	1-6
1.3. System Management .....	1-7
1.4. System Operating and Control Parameters .....	1-8
<b>2. SYSTEM INSTALLATION.....</b>	<b>2-1</b>
2.1. Site Review and Preparation .....	2-1
2.1.1. Site Review .....	2-1
2.1.2. Typical Mount Installation.....	2-3
2.2. Special Installation Situations .....	2-3
2.2.1. Parallel Systems.....	2-3
2.2.2. Short Reach Systems.....	2-4
2.3. Recommended Survey and Installation Tools and Test Equipment .....	2-5
2.4. Site Preparation .....	2-7
2.5. Installation Staffing .....	2-7
2.6. System Configuration .....	2-8
2.6.1. Introduction .....	2-8
Configuration Data.....	2-8
Customer Assigned IP Address Information .....	2-9
2.6.2. Hardware Configuration and Bench Testing before Installation .....	2-9
Bench Test Set Up - Equipment and Interconnection.....	2-10
Switch Configuration using the RS-232 Command Line Interface .....	2-11
Radio Configuration using a Crossover Cable .....	2-16
Optical Linkhead Configuration using a Crossover Cable .....	2-23
2.6.3. Hardware Configuration after Installation using the FlightManager XA GUI .....	2-25
PC Web Browser Connection.....	2-25
Switch Configuration using a Web Browser .....	2-26
Radio Configuration using a Web Browser .....	2-33
Linkhead Configuration using a Web Browser.....	2-35
2.7. Optical and RF Installation Components.....	2-37
2.7.1. Linkhead Optical Components .....	2-37
Universal Mount Hardware .....	2-37
Pan and Tilt Hardware .....	2-37
Power Supply Assembly.....	2-38
Linkhead Assembly .....	2-39
2.7.2. RF Components.....	2-40
RF Mounting Kit Assembly.....	2-40
Ethernet Cables.....	2-40
Power-Over-Ethernet (POE) Injector.....	2-41
Antenna and Radio .....	2-41
2.8. Assemble and Mount System Equipment.....	2-42

2.8.1. Optical Equipment .....	2-42
2.9. Assemble and Mount the Power Supply .....	2-45
2.10. Test Mount Stability .....	2-50
2.10.1. Mount Verification Test .....	2-51
2.10.2. Network Switch Setup .....	2-51
2.10.3. RF Equipment Setup .....	2-52
2.11. System Alignment .....	2-54
2.11.1. Automatic Beam Tracking and Power Control .....	2-54
2.11.2. Linkhead Alignment .....	2-56
2.11.3. Alignment Troubleshooting Tips .....	2-61
2.11.4. RF Antenna Alignment .....	2-62
2.12. Verify System Operation .....	2-66
2.12.1. Verify Optical System .....	2-66
2.12.2. Verify System Operation using FlightManager XA .....	2-68
<b>3. MAINTENANCE .....</b>	<b>3-1</b>
3.1. Scheduled Maintenance .....	3-1
3.1.1. Field of View .....	3-1
<b>4. TROUBLESHOOTING AND DIAGNOSTICS .....</b>	<b>4-1</b>
4.1. Fault Location .....	4-1
4.2. Failure Types .....	4-1
4.2.1. Network Component Problems .....	4-2
4.2.2. Environmental Problems .....	4-2
RF System Fresnel Zone .....	4-3
4.2.3. System Failures .....	4-4
4.3. Fault Isolation and Troubleshooting .....	4-5
4.4. Additional Troubleshooting Methods .....	4-7
4.4.1. Ping Test to Check Configuration .....	4-7
4.5. Network Monitoring .....	4-9
4.6. Technical Support .....	4-15
4.6.1. Checklist Before You Call Technical Support .....	4-15
4.7. Return Material Authorization (RMA) Procedure .....	4-16
<b>5. SPECIFICATIONS .....</b>	<b>5-1</b>
<b>6. INDEX .....</b>	<b>6-1</b>

## List of Figures

Figure 1-1: Dual Path Architecture.....	1-1
Figure 1-2: FlightStrata 100 XA Linkhead .....	1-3
Figure 1-3: Block Diagram of 4-Beam, 4-Receiver system.....	1-4
Figure 1-4: Lens Functions and Orientation .....	1-5
Figure 1-5: RF Unit.....	1-6
Figure 1-6: XA Switch.....	1-6
Figure 1-7: FlightManager XA GUI .....	1-7
Figure 2-1: Typical FlightStrata 100 XA Linkhead Mount Installation .....	2-3
Figure 2-2: Parallel Linkhead Systems.....	2-3
Figure 2-3: Angled Linkhead Systems .....	2-4
Figure 2-4: FlightStrata 100 XA Bench Test Interconnect Diagram.....	2-10
Figure 2-5: Universal Mount Hardware .....	2-37
Figure 2-6: Pan and Tilt Hardware .....	2-37
Figure 2-7: Power Supply Assembly .....	2-38
Figure 2-8: Linkhead and Pan and Tilt Assemblies.....	2-39
Figure 2-9: RF Mounting Clamps .....	2-40
Figure 2-10: Waterproof Cabling Gland .....	2-40
Figure 2-11: Power-Over-Ethernet (POE) Injector .....	2-41
Figure 2-12: Antenna and Radio.....	2-41
Figure 2-13: Three Types of Mount Movement.....	2-50
Figure 2-14: Mount Stability Tests .....	2-50
Figure 2-15: Automatic Tracking .....	2-54
Figure 2-16: Linkhead Back Panel.....	2-66
Figure 4-1: RF Fresnel Zone .....	4-3
Figure 4-2: Normal Back Panel Display.....	4-4
Figure 4-3: Troubleshooting Flowchart (Part 1).....	4-5
Figure 4-4: Troubleshooting Flowchart (Part 2).....	4-6
Figure 4-5: Ping Test Setup .....	4-7

## List of Tables

Table 1-1: FlightManager XAScreen Buttons.....	1-7
Table 1-2: System Operating and Control Parameters .....	1-8
Table 2-2: Beam width over distance .....	2-4
Table 2-1: Bench Test Components and Required Network Information.....	2-8
Table 2-2: Customer Assigned IP Addresses.....	2-9
Table 2-3: FlightPower Options .....	2-38
Table 2-4: Linkhead Back Panel Displays, Controls, and Indicators .....	2-66
Table 2-5: Bar graph and LED Operational Checks .....	2-67
Table 4-1: Networking Equipment Problems.....	4-2
Table 5-1: FlightStrata 100 XA System Specifications.....	5-1

## Optical Safety

Free-Space Optical (FSO) systems incorporate semiconductor lasers as transmission sources. You must be aware of corresponding laser safety regulations and take the necessary precautions to avoid close direct exposure to the laser beam(s). The infrared laser beam is invisible and has the potential to penetrate to the retina and cause thermal damage. These optical systems use a Class 1M laser in accordance with the international laser safety standard IEC/EN 60825-1 A2:2001. These optical systems use a Class 1M laser in accordance with the international laser safety standard IEC/EN 60825-1 A2:2001.

Familiarize yourself with laser safety regulations and strictly enforce all necessary precautions.



**Warning:** Do not look directly into the laser aperture from a short distance. Never use any optical instruments to view the laser beam.

When using the built-in telescope, you must be aware of the appropriate safety distance (refer to the following table). For distances below the safety distance the operator must wear appropriate eye-protective laser safety glasses. These distances assume an exposure of more than ten seconds.

### Safe Distances for Telescope Operation

Linkhead	Naked Eye safety distance	Telescope safety distance
FlightStrata 100 XA	0 m	14 m (45 ft)

Multiple beam FlightStrata 100 XA transmits laser radiation from four separated transmission apertures.



**Caution:** Use of controls or adjustments or performance of procedures other than those specified herein may result in hazardous radiation exposure.



**Caution:** This is a Class 1M Free-Space Optical Communication System (FSOCS) transmitter and may be installed in *unrestricted*, *restricted* or *controlled* locations. For additional details, please refer to IEC 60825: SAFETY OF LASER PRODUCTS Part 12: Safety of free space optical communication systems used for transmission of information.

Unrestricted locations are those areas that are normally accessible to the public (e.g., unrestricted areas of rooftops, public areas at ground level, open areas of offices and industrial premises, etc.). To install a LightPointe FSO system in an unrestricted location, the linkhead must be installed 3 meters high or higher above the surface of the unrestricted area or must be 1 meter or closer to the edge of the unrestricted area. If a LightPointe FSO system is installed in an unrestricted area, a warning sign must be posted that states "Do not use binoculars, telescopes or other optical aids to view the FSO linkheads."

Restricted locations are those areas that are normally inaccessible by the general public (including workers, visitors, and residents in the immediate vicinity) by means of any administrative or engineering control measure but that is accessible to authorized personnel (e.g. maintenance or service personnel including window cleaners in exterior locations) that may not have laser safety training. There are no special requirements for a LightPointe FSO system installed in a restricted area.

Controlled locations are those locations where any kind of engineering or administrative control measure is introduced to make it inaccessible except to authorized personnel with appropriate laser safety training (e.g., tower-mounted terminals, fenced/secure areas of rooftops, locked rooms with strictly-controlled access, etc.). There are no special requirements for a LightPointe FSO system installed in a controlled area.

The laser system shall be installed in accordance with ANSI Z136.1 control measures (engineering, administrative, and procedural controls).

### **Laser Safety Labels**

All relevant labels are affixed to the linkheads as required by the agencies responsible for the oversight of Free Space Optics products. These identification and warning labels are affixed to the outer shell of the linkhead:

- ❑ Product label with details on company name, product information and specific compliance data, normally affixed to the side of the linkhead
- ❑ Laser classification product label with caution comments, normally affixed to the side of the linkhead
- ❑ Aperture label indicating that invisible laser radiation is being emitted, normally affixed near the transmission point of the linkhead



**Caution:** Do not modify this certified laser product.

## Laser Safety Contact Information

Laser Safety in the United States is regulated by the Food and Drug Administration's Center for Devices and Radiological Health (FDA/CDRH). The FDA enforces laser performance standards within the US. The FDA may be contacted at:

U.S Department of Health and Human Services  
Food and Drug Administration  
Center for Devices and Radiological Health  
2094 Gaither Road  
Rockville, MD 20850  
<http://www.fda.gov/cdrh>

## Safety

### Electrical Guidelines

Observe the following electrical guidelines when working on the FlightStrata 100 XA product:

- ❑ Do not work on the system or disconnect cables during thunderstorms, when power is applied, or while wearing wool clothing.
- ❑ Do not touch the power supply when the power cord is connected. Because the product doesn't have a power switch, line voltages are present within the power supply when the power cord is connected to the product.
- ❑ The product relies on the building's installation of short-circuit (overcurrent) protection. Make sure that a fuse or circuit breaker not larger than 120 VAC, 15A U.S. (240 VAC, 10A international) is used on all current-carrying conductors.
- ❑ Before working on the unit, unplug the power cord from the AC outlet or disconnect the fuse or circuit breaker.
- ❑ Locate the emergency power-off switch for the AC source connected to the product. If an electrical accident occurs, use this switch to turn off power to the product.
- ❑ Identify possible hazards in your work area, such as moist floors, ungrounded power extension cables, and missing safety grounds. Do not work alone if potentially hazardous conditions exist.
- ❑ Ungrounded or improperly grounded antennas constitute a hazard to personnel and equipment. A lightning strike on a near an improperly grounded antenna can cause severe injury or death as well as equipment destruction.

### General Safety Guidelines

Observe the following general guidelines to ensure safety:

- ❑ Keep tools away from walk areas where personnel could trip over them.

- ❑ Do not wear loose clothing that could get caught in the chassis mounting hardware. Fasten your tie or scarf and roll up your sleeves.
- ❑ Wear safety glasses when working under any conditions that might be hazardous to your eyes.
- ❑ Do not perform any action that creates a potential hazard to people or makes the equipment unsafe.
- ❑ Antenna cables should be listed for outdoor installation in accordance with the National Electric Code, or acceptable to the local Authority Having Jurisdiction.
- ❑ Regulatory Information

## **RF Regulatory Information**

This RF product operates in the 5.8 GHz band (modified 802.11a), complies with the IEEE 802. ID MAC bridging standard and supports SNMP monitoring if IP routing is enabled.

### **FCC Radio Frequency Interference Statement**

#### **FCC ID: KA324WAN6**

The RF product is certified to comply with Part 15 of Federal Communications Commission (FCC) Rules. Operation is subject to the following two conditions:

1. It may not cause harmful interference.
2. It must accept any interference that may cause undesired operation.

### **Industrie Canada Radio Frequency Interference Statement**

#### **CANADA 2499391192A**

The RF product is certified to comply with Industrie Canada (IC) RSS/CNR 139. Operation is subject to the following two conditions:

1. It may not cause harmful interference.
2. It must accept any interference that may cause undesired operation.

### **Other Countries**

Although the product uses a modified 802.11a radio operating in the 5.8 GHz frequency, it may not be considered an unlicensed radio in your country. Please check with your local government or municipality to ensure safe and legal operation of the system.

## Radio Transmission Notice

The RF product is a low power (less than 1 Watt) direct-sequenced, spread-spectrum radio system pre-set to transmit and receive signals in the 5.3 – 5.8 GHz frequency band. The RF product has been certified by the U.S. Federal Communications Commission for use in the United States of America in that band. The manufacturer makes no representation as to the availability of the above-mentioned frequency band for such use in other countries.

Any prospective user of this product outside the United States of America should, prior to such use contact the government department responsible for assigning radio frequencies in the country in which use is proposed to determine whether such department or agency has any objection to the operation of the RF product in the 5.3 to 5.8 GHz bandwidth, and whether there are any other local devices generating signals in the band which might be expected to interfere with the operation of this product.

LightPointe shall not be responsible for any operation of the RF product which is in violation of local law, creates interference harmful to other local devices, or results in a malfunction of this product caused by outside interference.

**In order to comply with FCC RF exposure requirements, a minimum separation distance of 27 inches must be maintained between the antenna and any persons.** When installing the antenna, ensure that this clearance is maintained while the product is in operation.

This product must be installed and used in strict accordance with the manufacturer's instructions. However, there is no guarantee that interference to radio communications will not occur in a particular commercial installation. In case the product does cause harmful interference with an authorized radio service, the user/operator shall promptly stop operating the device until harmful interference has been limited. LightPointe is not responsible for any radio or television interference caused by unauthorized modification of this device or the substitution or attachment of connecting cables and equipment other than specified by LightPointe. The correction of interference caused by such unauthorized modification, substitution, or attachment will be the responsibility of the user.

## Declaration of Conformity

LightPointe declares that the RF product, manufactured 2001-2005, conforms to the following product specifications:  
EMC-CISPR22 Class A, IEC 60417, UL 94, CFR47 Part 15, UL 1950, CSA22.2 No. 950-M95, RSS 210, Low Voltage Directive including amendments by CE Marking Directive.

## **Service**

There are no serviceable parts within the units and the linkheads and radios should not be opened in the field. Only factory trained personnel can provide service on any internal components of the linkheads or radios.

## **Warranty**

LightPointe warrants this product against faulty materials or workmanship under the terms of our current Standard Warranty And Support Agreement provided that the product was purchased directly from us or from one of our authorized resellers. Please contact LightPointe Customer Service for additional information or to obtain a copy of the Warranty Agreement.

## **Contacting LightPointe**

### **Corporate Office**

10140 Barnes Canyon Road, San Diego, CA 92121  
Phone: 858.643.5200, Fax: 858.643.5201

### **Technical Support**

Phone: (U.S.) 858.643.5299

Website: [www. LightPointe.com](http://www.LightPointe.com)

Email: [techsupport@LightPointe.com](mailto:techsupport@LightPointe.com)

## Using This Manual

This manual describes how to install and maintain the FlightStrata 100 XA systems.

Step-by-step procedures describe:

- ❑ Performing a site review
- ❑ Installation preparation
- ❑ Preparing an installation site
- ❑ Performing hardware installation
- ❑ Performing system interconnection and alignment
- ❑ Performing hardware configuration using both a Command Line Interface and Web Browser method
- ❑ Checking the system for proper operation
- ❑ Performing troubleshooting procedures

<b>Section</b>	<b>Contents</b>
1. System Overview	System functional and physical overview
2. System Installation	Detailed step-by-step installation, configuration, and alignment procedures
3. Maintenance	Activities required to maintain the system
4. Troubleshooting and Diagnostics	Resolving operational problems
5. Specifications	Physical and electrical specifications
6. Index	Keyword index

## Additional Resources

Refer to the following documents for additional information about the LightPointe system.

<b>Document Number</b>	<b>Title</b>
505-015902-00000	Field Engineering and Planning Guide

# 1. System Overview

---

This chapter covers the following main topics:

- ❑ System Introduction
- ❑ System Components
- ❑ System Management
- ❑ System Operating and Control Parameters

## 1.1. System Introduction

### 1.1.1. DualPath™ Architecture

The LightPointe FlightStrata 100 XA is based on a patented DualPath architecture which combines a high bandwidth Optical Wireless link, a robust RF backup, sub-second intelligent switching and key network management features. The end result is unprecedented 99.999% network availability at distances up to 5 km – even in the most extreme weather conditions, including fog.

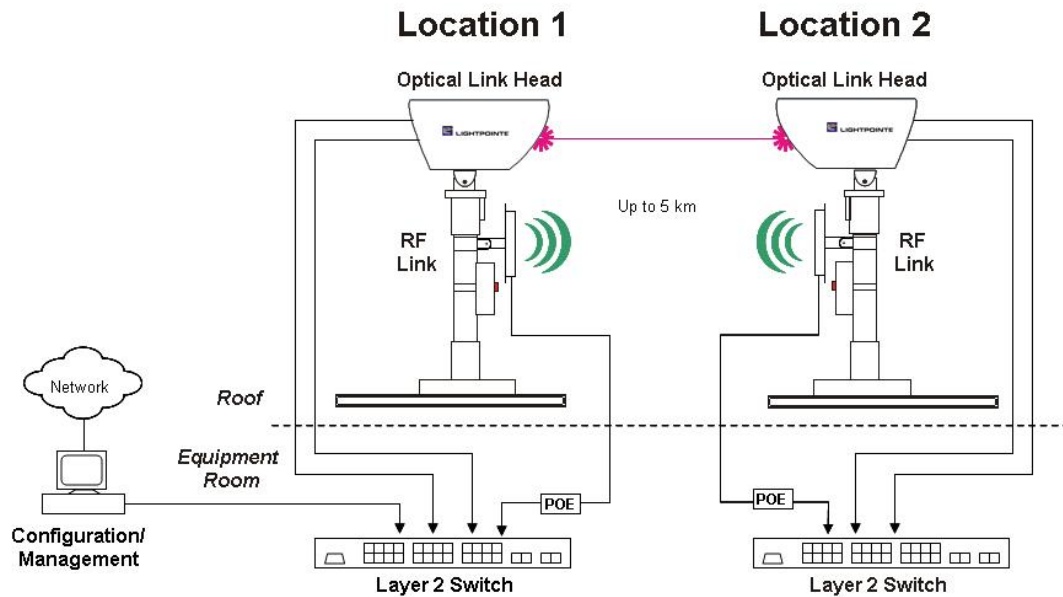

**Figure 1-1: Dual Path Architecture**

### Free-Space Optical Transmission (Primary Link)

The LightPointe FlightStrata 100 XA primary means of communications is optical wireless using multi-beam infrared light (invisible to the human eye). The link systems require “true” line-of-sight between locations or relay locations (hopping points) and operate in high and ultra-high bandwidths.

The linkhead on the transmission side transmits a narrow infrared light beam carrying the data received from the network interface. The linkhead on the opposite side receives the beam, filters the optical signal, and transfers it to the network fiber interface on the receiving side. The system is capable of operating in a full-duplex mode, transmitting and receiving data simultaneously.

### **Radio Frequency (Secondary Link)**

In the event of primary link failure, the LightPointe FlightStrata 100 XA uses integrated 5.8 GHz radios and antennas as a backup wireless link. Unlike Optical Wireless transmission, these wireless LAN radios are specifically designed to provide communications in “near-line-of-site” environments, but obstacles such as trees, buildings or other potential sources of interference must be considered.

As with traditional Ethernet LANs, wireless LANs are based on a Carrier Sense Multiple Access network protocol. But unlike Ethernet which implements a Collision Detection scheme (where data is retransmitted if a collision is detected), wireless LANs implement a Collision Avoidance scheme (where data is only sent when the air is free). This CSMA/CA protocol, as defined, does not allow for simultaneous, two-way traffic. Thus, while Optical Wireless solutions are full-duplex, RF solutions are, by their very nature, half-duplex.

The RF backup uses power-over-Ethernet to simplify installations.

### **Switching**

The intelligence behind the DualPath Architecture lies in its switching capabilities. In the event of a primary optical link failure, a Layer 2 hardware appliance seamlessly switches the data transmission to the secondary RF link, thereby maintaining connectivity. When the optical link is restored, the data transmission is switched back to the primary link.

A patented switching algorithm helps resolve a common switching issue known as “flapping”. In unstable environments (such as fog) where optical signals can continuously fluctuate, the connection may be lost several times in the matter of a few seconds. Instead of switching back and forth between the primary and secondary links in this short amount of time, a “hold-off time” is implemented. Only when the optical link is stable for a specified time period will the transfer from secondary link back to primary link take place. Furthermore, the optical link must be lost for a designated time period before transfer to the secondary RF link, thereby avoiding instances where a bird, for example, temporarily breaks the optical path.

### **Configuration and Management**

The FlightStrata 100 XA also includes a Web-based tool for configuration and management of the primary Optical path, the secondary RF path, and the seamless Layer 2 XA Switch. Network management features such as SNMP traps/alarms, Quality of Service (QoS), and traffic prioritization are also available.

### 1.1.2. Typical Applications

The FlightStrata 100 XA is ideal for bandwidth-intensive, mission-critical applications such as:

- ❑ Enterprise/LAN solutions (Point-to-point connectivity between buildings, campuses, remote locations)
- ❑ Wireless backhaul
- ❑ Metro network extension
- ❑ Voice-Over-IP
- ❑ Medical imaging
- ❑ CAD/Graphics design and video.

### 1.1.3. Network Interface Connectivity

FlightStrata 100 XA linkheads and radios are equipped with RJ-45 ports while the XA switch includes 24 10/100/1000BaseT ports and 4 Combo SFP/Mini-GBIC ports for easy connectivity to an existing customer network.

## 1.2. System Components

### 1.2.1. Optical Components

FlightStrata 100 XA linkheads are multi-beam transmitter/receiver systems.



**Figure 1-2: FlightStrata 100 XA Linkhead**

The linkheads in this product line include the following main components:

- ❑ Front window/lens heater and defroster
- ❑ Multi-beam optical assembly with optical fiber connections
- ❑ Integrated telescope for coarse alignment of the system
- ❑ Receive amplifier with avalanche photo diode (APD)
- ❑ Integrated automatic beam alignment and automatic gain control (receiver power control)
- ❑ Transmitter amplifier with 4 Vertical Cavity Surface Emitting Lasers (VCSELs)
- ❑ Optical management interface card (OMI)
- ❑ Power supply with external connectors
- ❑ Back panel with system status display and optical level meter

### Optical System Block Diagram

FlightStrata 100 XA systems use four transmission beams and four receiver lenses to provide signal redundancy.

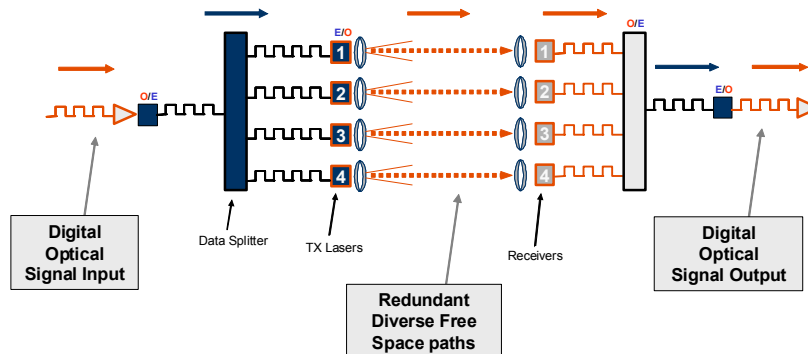

**Figure 1-3: Block Diagram of 4-Beam, 4-Receiver system**

A multi-beam, multi-path optical design is utilized to provide spatial and path diversity. The transmission and receive optics are positioned to make optimum use of the entire front surface of the linkhead. The sub-assemblies that perform electro-optic conversion are arranged around the optical portion of the system. The system uses multi-beam optical design geometries and a 22.5° alignment rotation of the transmitter and receiver lenses to improve beam alignment.

### Transmission Components

Optical signals from the data network are received at the Data Transceiver and converted to four identical data streams. Four VCSEL lasers convert the electrical signals into optical signals that are transmitted as four infrared beams into free-space.

## Receiver Components

The receive amplifier converts the infrared signals coming from the free-space path into an electrical signal which drives the optical Network Transceiver sending the original signal to the data network at the far end..

## Multi-Beam Array Tracking and Automatic Gain Control

The Multi-Beam Tracking (MBAT) capability counteracts the slow but high amplitude movements that are experienced with most installations, normally due to diurnal expansion and contraction effects. The Automatic Gain Control (AGC) delivers performance to address changing atmospherics by controlling the amount of energy that is received at each linkhead. The combination of rotational optics, MBAT and AGC means even greater link margins, which translate into improved system performance.

## Lens Geometry

The small transmit lenses and large receive lenses are positioned for perfect alignment between Transmitters and Receivers at all distances, including short distance shots.

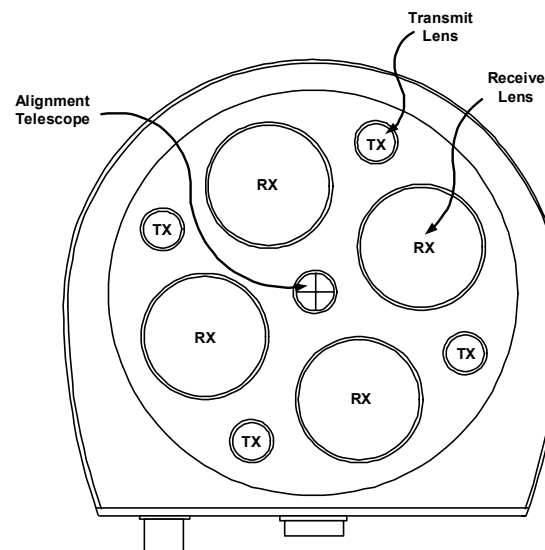

**Figure 1-4: Lens Functions and Orientation**

### 1.2.2. RF Components



**Figure 1-5: RF Unit**

The FlightStrata 100 XA RF secondary link consists of the following main components:

- ❑ Radio and flat panel antenna integrated into ruggedized 12 in x 12 in x 3 in waterproof chassis
- ❑ Mounting bracket
- ❑ 3-inch extension arm
- ❑ Power-over-Ethernet injector with power supply and power cords

### 1.2.3. XA Switch Components



**Figure 1-6: XA Switch**

The FlightStrata 100 XA Switch consists of the following main components:

- ❑ 24-port auto-sensing Layer 2 switch
- ❑ Console cable (RS232)
- ❑ Power cord

### 1.3. System Management

FlightManager XA is a point and click web-based software tool that displays real-time windows that are used to monitor and configure the primary Optical path and the secondary RF path on both the root and peer systems. Web-based Configuration/Monitoring Tools include:

- ❑ Configuration of network, RF and security parameters such as IP Addresses and Subnet Masks
- ❑ Real-time RF and Optical signal strength gauge
- ❑ Transmit and receive error information
- ❑ Visual display of path being used
- ❑ System name, model, and serial number information

The following figure illustrates the main screen of the FlightManager XA graphical user interface (GUI) utilized for the FlightStrata 100 XA system.

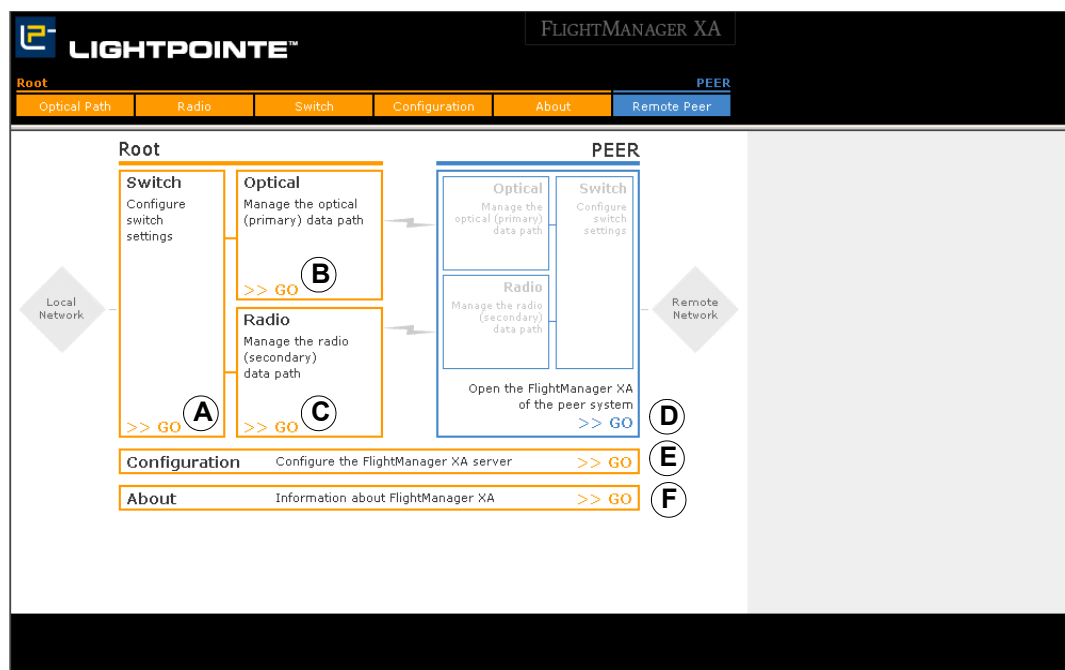

**Figure 1-7: FlightManager XA GUI**

**Table 1-1: FlightManager XAScreen Buttons**

Button	Description
A	Configure Root or Peer Switch operational settings
B	Observe Root or Peer Linkhead status information
C	Observe Root or Peer Radio status information
D	Open FlightManager XA on the opposite site (Building B)
E	Set Root or Peer Optical IP Address, Subnet Mask, Gateway Address and System IP Addresses (Pointers only)
F	Display FlightManager XA software version number

## 1.4. System Operating and Control Parameters

Refer to the following table for information about the FlightStrata 100 XA Linkhead, XA Radio, and XA Switch operating and control parameters.

**Table 1-2: System Operating and Control Parameters**

Parameters	Optical	XA Radio	XA Switch
Receivers/Transmitters	Four Receivers and Four Transmitters	Integrated Radio Panel Antenna	
Connectivity	Ethernet 10BaseT, 100BaseT	Ethernet 10BaseT, 100BaseT	Ethernet 10BaseT, 100BaseT, 1000BaseT, 100BaseFX
Interface	RJ-45 Copper Interface	RJ-45 Copper Interface	RJ-45 Copper Interface; SFP/Mini-GBIC
Data Rate	100 Mbps (Full Duplex)	72 Mbps (Half Duplex)	8.8 Gbps Switch Fabric
Operational Range	Up to 5 km (Line-of-Sight)	Up to 5 km (Line-of-Sight)	
Operating Power	40W	100mW (20 dBm)	
Operating Voltage	90 to 240V (50/60 Hz) Power-Over-Ethernet, Indoor 100 to 240V (50/60 Hz) or + 48V DC	Power-Over-Ethernet, Indoor DC Injector (24V, 1.5A)	100 to 240V (50/60 Hz)
Configuration and Management	HTTP	HTTP	HTTP, CLI/Console, SNMP v1, QoS, Load Balancing

## 2. System Installation

---

This chapter covers the following main topics

- ❑ Site review and preparation
- ❑ Recommended survey and installation tools and test equipment
- ❑ Site preparation
- ❑ Installation staffing
- ❑ System configuration
- ❑ Optical and RF installation components
- ❑ Assemble and Mount system equipment
- ❑ System alignment
- ❑ Verify system operation

### 2.1. Site Review and Preparation

Please refer to the LightPointe Field Engineering & Planning Guide for detailed site survey instructions. Use this guide to check the proposed installation against actual LightPointe installation standards.

#### 2.1.1. Site Review

- Step 1** Determine the appropriate system to meet the needs of each specific location:
- ❑ Data rate protocol
  - ❑ Measure point-to-point distance using a laser range finder or GPS
  - ❑ Are both the physical distance of the linkheads/antennas and the maximum transmission distance at the maximum?
- Step 2** Ensure optical/visual line-of-sight.
- ❑ Can emissions, trees, or other obstacles in the line of sight interrupt the connection?
  - ❑ Is there a possibility of work activity that could interfere with the transmission of data?
  - ❑ No vents, big flat roofs, or smoke stacks

**Step 3** Check RF line-of-sight and evaluate potential RF interference.

- Can trees or other obstacles in the line of sight interrupt the connection or encroach into the Fresnel zone? Is it possible to have visual line-of-sight without achieving RF line-of-sight? Also, keep in mind the time of year for foliage.
- Are there any other in-band 5.8 GHz RF products installed nearby that can potentially impact wireless spectrum usage?
- Are cellular devices, low frequency devices (TV, radio) or power lines nearby? These may cause interference.
- If necessary, use a spectrum analyzer or RF signal tester to check the RF environment and minimize interference risk

**Note:** The RF antenna and optical linkheads may be located at different locations on the roof to achieve line-of-sight.

**Step 4** Evaluate environmental mounting conditions.

- Stable and vibration-free mounting platform
- Foundation at the mounting location not susceptible to change due to humidity or temperature
- Evaluate the need for a lightning protection system (the RF antenna includes a built-in surge arrestor, but additional equipment may be required to protect other network components from lightning and other surges).
- Use non-penetrating roof mounting hardware if possible

**Step 5** Evaluate mounting locations for system access.

- Easy access to linkheads
- Stable location/platform for mounting
- Safety considerations for installers and maintainers of the system

**Step 6** Evaluate mounting locations for operational integrity (refer to Section 2.1.2 to see different types of mounts).

- Near roof edge to avoid interruptions of transmission and minimize heat (shimmer) effects
- Leave enough room on the mounting pole to mount the RF antenna below the linkhead
- Weather protected location if possible
- Personnel laser protection considerations

**Step 7** Consider the mount foundation (refer to Section 2.1.2).

- Penetrating
- Roof surface
- Wall
- Interior floor behind window

**Step 8** Consider mount type (refer to Section 2.1.2).

- Joint mount
- Other specialized mount

### 2.1.2. Typical Mount Installation

The RF antenna is normally mounted directly below the linkhead on the same mounting post. If a different linkhead mount is used, the RF antenna may be mounted differently than shown below.

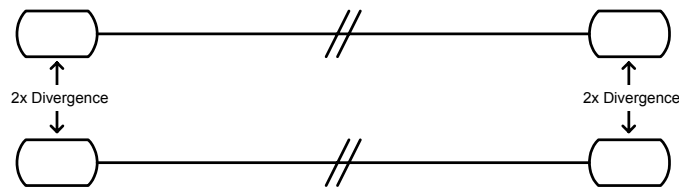

**Figure 2-1: Typical FlightStrata 100 XA Linkhead Mount Installation**

## 2.2. Special Installation Situations

### 2.2.1. Parallel Systems

Two LightPointe systems operating side by side may rarely interfere with each other, but only if operating on perfectly parallel paths. In practice this is extremely rare because a very small degree of separation is all that is required to eliminate this problem.



**Figure 2-2: Parallel Linkhead Systems**

If they are perfectly parallel, do not mount the linkheads of adjacent systems too close to each other. Maintain a distance of twice the beam width between linkheads per Table 2-2.

If the two systems are pointed in even slightly different directions (as little as one degree is enough to eliminate the problem) then the spacing of the linkheads is not a requirement because the field of view of the linkhead is very small and they will not interfere with each other in any way

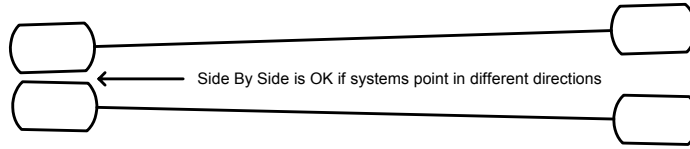

**Figure 2-3: Angled Linkhead Systems**

**Note:** It is not necessary to space the linkheads if systems are shooting at different angles

**Table 2-2: Beam width over distance**

Beam Divergence	Beam Width at 500 meters	Beam Width at 1000 meters	Beam Width at 2000 meters
2 milliradians	1 m	2 m	4 m
2.8 milliradians	1.4 m	2.8 m	5.6 m

**2.2.2. Short Reach Systems**

There are times when you wish to use the FlightStrata for a very short reach system. This most often happens in Laboratory or Demo situations, as well as for very short distance shots across a street or between close buildings.

The lens geometry is designed to accommodate this by giving perfect alignment between transmit and receive lenses at all distances. The Automatic Power control will also adjust the receiver power level to prevent saturation. So the system is designed for such short reach applications.

We have found in actual practice that the installation and alignment is much easier at distances greater than 40 meters where the beam size is large enough to begin to overlap across multiple lenses.

## 2.3. Recommended Survey and Installation Tools and Test Equipment

The following tools and supplies may be needed for survey, installation, testing, and maintenance of the LightPointe system hardware.

### Site Survey Tools:

- ❑ Thomas Guide or equivalent mapping tool for locating sites and doing rough distance calculations
- ❑ Laser range finder or GPS for accurate distance measurement
- ❑ Binoculars to assist in locating the planned opposite end installation location
- ❑ Sketch pad to make rough drawings and notes (recommend using LightPointe Field Engineering Guide)
- ❑ Tape measure to determine approximate short distance cabling, power runs, etc.
- ❑ Latitude and Longitude mapping software.
- ❑ Terrain mapping software (Micropath)
- ❑ Spectrum analyzer (Antitsu)
- ❑ Camera (digital recommended) to photograph installation sites to reduce need for return visits to sites (optional)

### Installation Tools:

- ❑ Standard electro-mechanical tool kit with pliers, screwdrivers, wire cutters, wire strippers, etc.
- ❑ Two-way radio or cell phones to communicate when aligning linkheads
- ❑ CAT-5 crimp tool and connectors
- ❑ Plastic tie wraps to secure flexible conduits, etc.
- ❑ Two each #6 hex wrenches to supplement wrenches shipped with the equipment
- ❑ Electrical tape for securing and fastening
- ❑ Measuring level to evaluate flatness of mounting surfaces
- ❑ Optical light generator and fiber tester to ensure fiber performance (optional)
- ❑ The tape measure and camera from the site survey can also be helpful in completing and documenting site installations

The following items may also be needed for installation and/or service, depending on the location and type of installation:

- ❑ Digital volt meter to check electrical systems
- ❑ Power drill or power hammer with appropriate bits to securely install the linkhead mounting platforms
- ❑ Step or extension ladder for access to elevated locations
- ❑ High quality rope to use for hoisting materials and/or to be used in conjunction with a safety harness to ensure installer safety when appropriate
- ❑ Exterior rated extension cord (50' or longer recommended)

## 2.4. Site Preparation

Please refer to the LightPointe Field Engineering & Planning Guide for detailed site preparation instructions.

### Step 1 Check space requirements.

- ❑ Multiple linkheads can be co-located at the same site. Depending on proximity, multiple linkheads should be spaced at least 3-meters (nine feet) apart if they are pointed in the same direction. There are no restrictions for linkheads pointed in different directions (refer to Section 2.2.1).

### Step 2 Prepare the surface for mounting.

- ❑ Inspect the surface to ensure that it is a solid material that can be penetrated by bolts.
- ❑ Make sure the surface is not cracked, broken, or spongy.
- ❑ Check the surface to ensure that it is rigid

### Step 3 Check the available power.

- ❑ Ensure that the power cable is long enough
- ❑ Use cable of correct diameter and rating
- ❑ Be aware of local building code requirement

### Step 4 Check the network interface connections.

- ❑ For each location, a total of 3 CAT-5 cable runs are required from the switch to the linkhead/antenna. Two CAT-5 connections are required for the linkhead and one CAT-5 connection is required for the antenna

### Step 5 Check CAT-5 cable routing.

- ❑ Make sure the correct cabling is used (outdoor rated recommended)
- ❑ Termination at linkhead and antenna side: CAT-5, RJ45
- ❑ Label all cables at both the roof location and switch location to distinguish between cable runs. If you accidentally plug the POE into the wrong port you may damage something.

## 2.5. Installation Staffing

A single person can perform all required installation and alignment procedures at most locations. However, installation can be completed more efficiently and safely if two people are used (one person at each linkhead).

## 2.6. System Configuration

### 2.6.1. Introduction

The FlightStrata 100 XA system is factory configured before delivery. The only configuration parameters that may require change are the hardware IP Addresses. When it becomes necessary to reconfigure the FlightStrata 100 XA system, you have the following two options for configuration procedures:

- ❑ To configure and bench test the system before installation, refer to Section 2.6.2. This approach uses the XA Switch Command Line Interface, and a Web GUI for radios and linkheads.
- ❑ To install the system and then configure the hardware, refer to Section 2.6.3. This approach uses a Web GUI to configure the switches, radios, and linkheads.

**Note:** The PC management console IP Addresses must be set to the addresses shown in Table 2-1.

### Configuration Data

The following table identifies the required components and network addresses (factory defaults) required to configure the FlightStrata 100 XA system.

#### IMPORTANT NOTE

**The FSA 100 XA system components (linkheads, switches and radios) have been customized and preconfigured to ensure optimal performance in LightPointe-specific Optical Wireless installations. Any changes to default settings, port assignments, use of advanced switch features or use of non-LightPointe linkheads or radios may impact system operation and will not be supported by LightPointe.**

**Table 2-1: Bench Test Components and Required Network Information**

Components	Number Required	IP Address	Description
Laptop Management Console	1 Minimum	(Customer Assigned = XXX) Local: 192.168.1.XXX Peer: 192.168.1.XXX	Pentium 4 or equivalent
LightPointe Ethernet XA Switch	2	(Factory Configured) Local: 192.168.1.102/24 Peer: 192.168.1.202/24	Layer 2 switch
FlightStrata 100 XA Radio and Flat Panel Antenna	2	(Factory Configured) Local: 192.168.1.101 Peer: 192.168.1.201	Secondary communications link
FlightStrata 100 XA Linkhead (Data Port)	2	Transparent Bridge	Primary communications link
FlightStrata 100 XA Linkhead (Management Port)	2	(Factory Configured) Local: 192.168.1.100 Peer: 192.168.1.200	Management Interface

## Customer Assigned IP Address Information

Please record customer assigned IP address information in this section before beginning equipment configuration and installation. Information can also be written on the diagram in Figure 2-4 for easy reference.

**Table 2-2: Customer Assigned IP Addresses**

Customer Configurable Component	Customer Assigned IP Address
Root Laptop Management Console:	_____
Peer Laptop Management Console (Optional):	_____
Root LightPointe Ethernet XA Switch:	_____
Peer LightPointe Ethernet XA Switch:	_____
Root FlightStrata 100 XA Radio:	_____
Peer FlightStrata 100 XA Radio:	_____
Root Linkhead Management Port:	_____
Peer Linkhead Management Port:	_____
(Optional) SNMP Server:	_____

### 2.6.2. Hardware Configuration and Bench Testing before Installation

If you want to reconfigure parameters and verify the operation of your system before installation, use the procedures in this section.

#### IMPORTANT NOTE

**The FSA 100 XA system components (linkheads, switches and radios) have been customized and preconfigured to ensure optimal performance in LightPointe-specific Optical Wireless installations. Any changes to default settings, port assignments, use of advanced switch features or use of non-LightPointe linkheads or radios may impact system operation and will not be supported by LightPointe.**

## Bench Test Set Up - Equipment and Interconnection

The following figure illustrates how to set up the FlightStrata 100 XA system for bench testing and component pre-configuration.

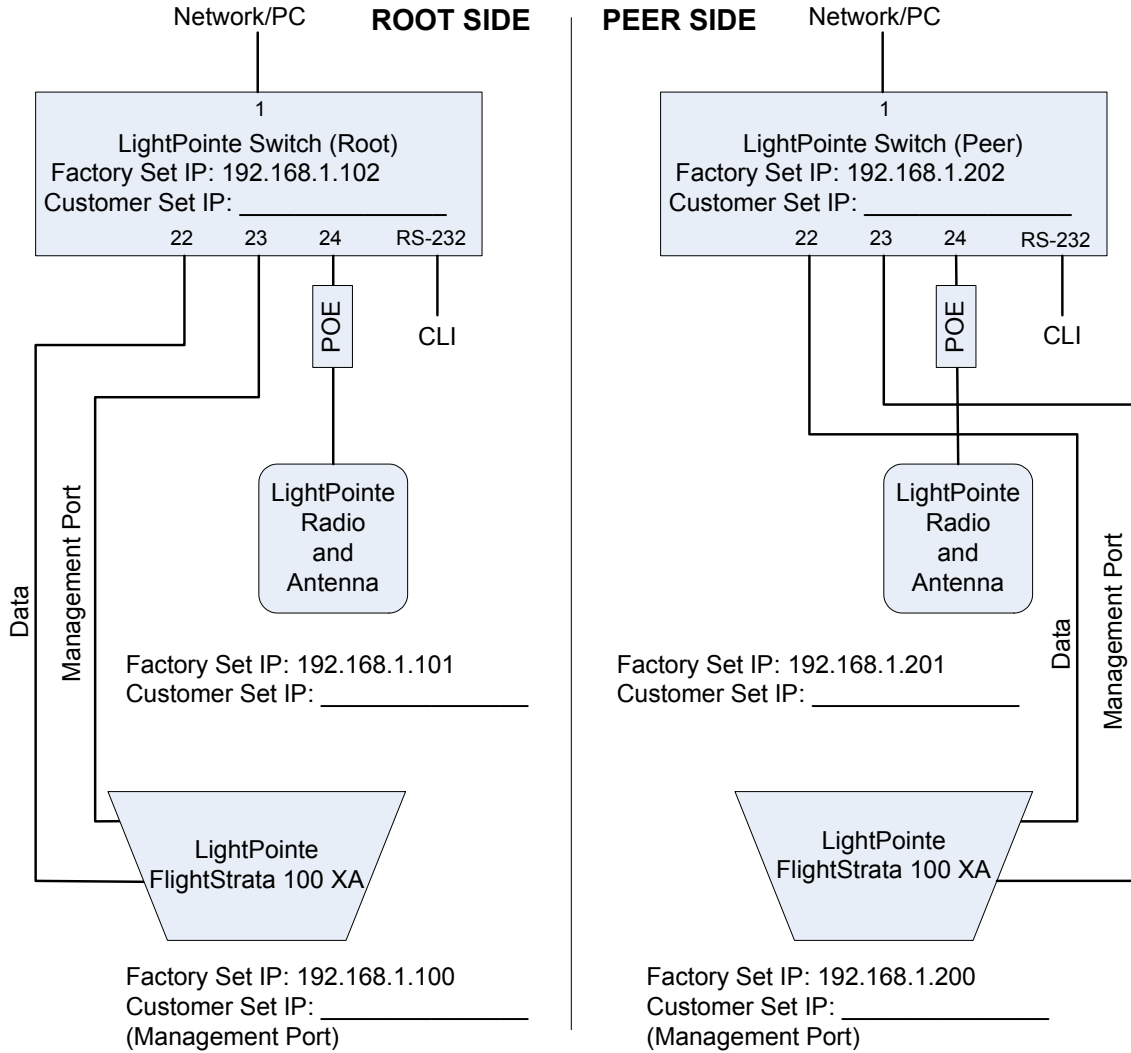

**Figure 2-4: FlightStrata 100 XA Bench Test Interconnect Diagram**

## Switch Configuration using the RS-232 Command Line Interface

LightPointe uses the LFSW-3226L switch to support its dual path solution. The LightPointe switch can be configured by using either a Command Line Interface (CLI) or a Web based browser interface. Configuring the switch includes the following tasks:

- Set Network IP Address
- Set Per Port data rate limitation
- Enable ports 1, 22 - 24, and disable all other ports
- RSTP Setup
- VLAN QoS setup
- SNMP (Simple Network Management Protocol) setup

You can connect to the switch's management agent via the CLI serial port on the switch and a terminal or through a computer running a terminal emulation program.

### IMPORTANT NOTE

**When you use HyperTerminal with the Microsoft® Windows® 2000 operating system, ensure that you have Windows 2000 Service Pack 2 or later installed. Windows 2000 Service Pack 2 allows you to use arrow keys in HyperTerminal's VT100 emulation.**

### RSTP Set up

To set up the switch to utilize Rapid Spanning Tree Protocol, perform the following steps on both the peer and root switches. All CLI comments are preceded by two forward slashes (i.e. // comment).

**Step 1** Ensure the bench test system is interconnected as shown in Figure 2-4. Double check switch port usage:

- Port #1 - Connected to a Network/PC
- Port #22 - RF Unit (STP Enabled)
- Port #23 - Linkhead Management
- Port #24 - Linkhead Data (STP enabled)

**Step 2** Connect a 9-pin RS-232 serial port between the PC serial port and the CLI serial port on the front panel of each LFSW-3226L switch.

**Step 3** Ensure the PC serial port is configured as follows:

- 9600 baud
- no parity
- 8 data bits
- 1 stop bit
- Flowcontrol none

**Step 4** Start up a HyperTerminal on the PC. With the serial port and computer properly connected, the following screen should appear.

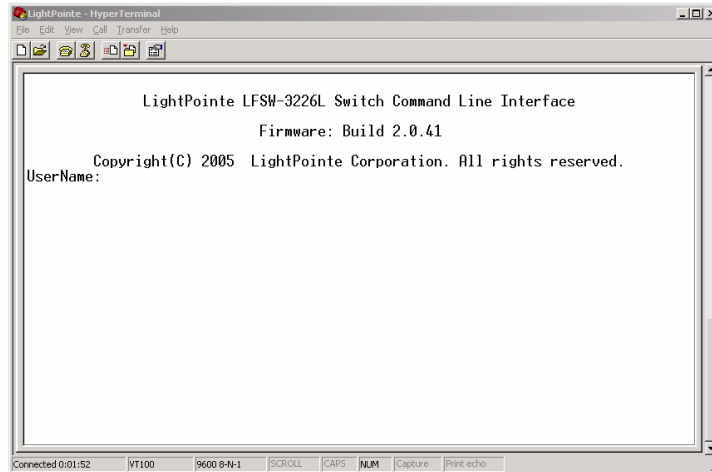

**Step 5** Press the Enter key twice. The CLI cursor **LFSW-3226L:4#** is displayed. This is the command line from which all of the following CLI commands are input.

**Step 6** The following CLI commands can be used to display the status of the switch:

- Display information about the switch  
**LFSW-3226L:4#show switch**
- Display the IP address  
**LFSW-3226L:4# show ipif**
- Display the port status  
**LFSW-3226L:4# show ports**
- Display STP settings  
**LFSW-3226L:4# show stp**
- Display STP port settings  
**LFSW-3226L:4# show stp ports**

- Step 7** Configure the IP Addresses of the Near and Peer Switches. You must use the customer IP addresses. The addresses shown below are the factory default settings.
- Local:  
**LFSW-3226L:4#config ipif System ipaddress 192.168.1.102**
  - Peer:  
**LFSW-3226L:4#config ipif System ipaddress 192.168.1.202**
- Step 8** Enable port 22 for Fast Ethernet and disable ports 2-21, 25-26.
- LFSW-3226L:4#config ports 22 speed 100\_full**
  - LFSW-3226L:4#config ports 2-21, 25-26 state disable**
- Step 9** Configure the switch Spanning Tree Protocol settings for both switches.
- LFSW-3226L:4#enable stp**
  - Globally enable STP on switch for rapid spanning tree protocol.  
**LFSW-3226L:4#config stp version rstp**
  - Set the maximum amount of time (in seconds) that the switch will wait to receive a BPDU packet before reconfiguring STP.  
**LFSW-3226L:4#config stp maxage 6**
  - Set the maximum amount of time (in seconds) that the root device will wait before changing states.  
**LFSW-3226L:4#config stp forwarddelay 4**
  - The time interval between transmission of configuration messages by the root device.  
**LFSW-3226L:4#config stp hellotime 1**
  - Set the maximum number of Hello packets transmitted per interval. The count can be set from 1 to 10.  
**LFSW-3226L:4#config stp txholdcount 10**
  - Allow the forwarding of STP BPDU packets from other network devices when STP is disabled on the switch.  
**LFSW-3226L:4#config stp fbpdu disable**
  - Root side - A numerical value between 0 and 61,440 that is used in determining the root device, root port, and designated port. The device with the highest priority becomes the root device. The lower the numerical value, the higher the priority.  
**LFSW-3226L:4#config stp priority 4096**
  - Peer side  
**LFSW-3226L:4#config stp priority 8192**
  - LFSW-3226L:4#config stp ports 22 priority 16**
  - LFSW-3226L:4#config stp ports 26 state disable**
  - LFSW-3226L:4#config stp ports 23 edge true**
  - LFSW-3226L:4#config stp ports 1 edge true**
  - Set the transmit bandwidth of port 24 to 15 Mbps.  
**LFSW-3226L:4#config bandwidth\_control 24 tx\_rate 192**
- Step 10**  Save all settings.  
**LFSW-3226L:4#save**

## Optional QoS Set up (Priority Queuing of Frame Packet Data)

### IMPORTANT NOTE

**The switch is rate-limited for optimal use in combination data and voice environments. If data-only traffic is being transmitted, turning the switch QoS features off will result in higher throughput. Furthermore, all ports should be in Auto Negotiation mode to ensure highest throughput.**

Ports 1, 22 -24 are by default set as VLAN ports. The QoS (Quality of Service) CLI commands are used to set up the switch to utilize 802.1p priority queuing. Perform the following steps to implement priority queuing on both the far and local switches.

- Step 1** The switch default state is QoS On. The following settings are examples only. The actual settings are all customer network specific.
- Create vlan on the switch named "voip" with ID of "2".  
**LFSW-3226L:4#create vlan voip tag 2**
  - Create vlan on the switch named "data" with ID of "3".  
**LFSW-3226L:4#create vlan data tag 3**
- Step 2**
- Add ports to the port list of a previously configured vlan "default".  
**LFSW-3226L:4#config vlan default add tag 1, 22-24**  
  
Add ports to the port list of a previously configured vlan "voip".  
**LFSW-3226L:4#config vlan voip add tag 1, 22-24**  
  
Add ports to the port list of a previously configured vlan "data".  
**LFSW-3226L:4#config vlan data add tag 1, 22-24**
- Step 3**
- Save all settings.  
**LFSW-3226L:4#save**

## Optional SNMP Set up (Version 1 or 2c)

The LFSW-3226L switch supports the Simple Network Management Protocol (SNMP) versions 1, 2c, and 3. You can specify which version of the SNMP you want to use to monitor and control the switch. Perform the following steps on both the Local and Peer switches.

- Step 1** The following settings are examples only. The SNMP server in the following example has an IP address of 192.168.1.106. The actual SNMP server IP address is customer network specific.
- Enable SNMP traps.  
**LFSW-3226L:4#enable snmp traps**
  - Optional - Create a recipient of SNMP traps generated by the switch's SNMP, set the SNMP version to v2c, and specify packet authorization and encryption.  
**LFSW-3226L:4#create snmp host 192.168.1.106 v2c private**
  - Optional - Same as above command except SNMP version v1 is used.  
**LFSW-3226L:4# create snmp host 192.168.1.106 v1 private**
- Step 2**
- Save all settings.  
**LFSW-3226L:4#save**

## Radio Configuration using a Crossover Cable

As required by the installation, the factory default radio configuration settings can be changed using the following procedure.

### IMPORTANT NOTE

**The FSA 100 XA system components (linkheads, switches and radios) have been customized and preconfigured to ensure optimal performance in LightPointe-specific Optical Wireless installations. Any changes to default settings, port assignments, use of advanced switch features or use of non-LightPointe linkheads or radios may impact system operation and will not be supported by LightPointe.**

- Step 1** Connect a crossover ethernet cable between each radio ethernet port and the ethernet port on a PC.

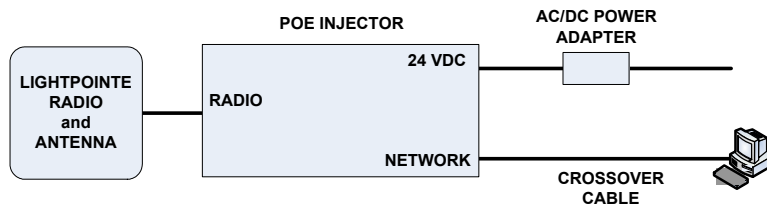

**Note:** The PC management console IP Addresses must be set to the addresses shown in Table 2-1.

- Step 2** Start up a Browser on the PC.
- The linkheads can be configured using a web browser such as Netscape® Navigator (version 6.2 and higher) or Microsoft® Internet Explorer (version 5.0 and higher)

- Step 3** To access the radio, at the browser URL address line enter the appropriate radio default IP address (see Table 2-1, Table 2-2 or Figure 2-4).  
From the Welcome screen click on **Login**, the Password window is displayed.

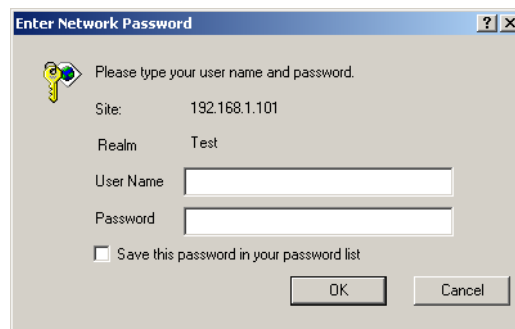
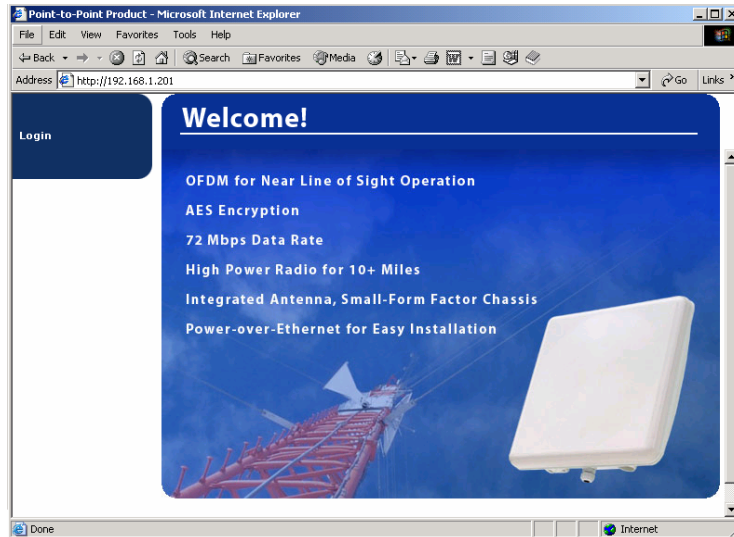

**Step 4** Enter **User Name** and **Password** and click the **OK** button. The Root radio Main Status window is displayed.

- The default user name is admin and the default password is default.

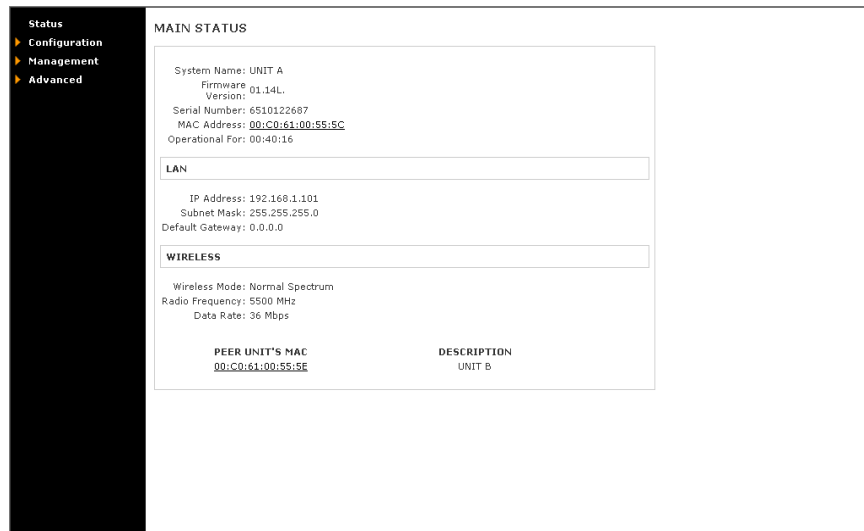

Locate the following Root radio status information:

- Name, firmware version, serial number, MAC address
- LAN address data and wireless mode of operation

**Step 5** To check the Root radio receive and transmit data status, click on the upper MAC address. The Root Radio Status window is displayed.

- Click the Back button to return to the Main Status window.

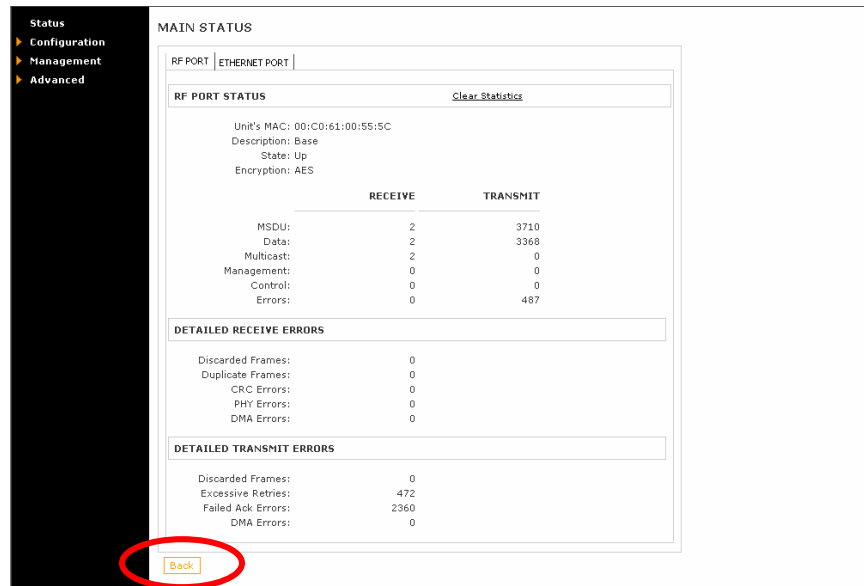

- Step 6** To check the peer radio port and receive and transmit data status, click on the lower MAC address. The Peer Radio Status window is displayed.

The screenshot shows the 'MAIN STATUS' window with a sidebar on the left containing 'Status', 'Configuration', 'Management', and 'Advanced'. The main content area is titled 'PEER'S RF PORT STATUS' and contains two identical sections for different radio ports. Each section includes a 'Signal Level' bar and a table of statistics.

	RECEIVE	TRANSMIT
MSDU:	2	3992
Data:	2	4113
Multicast:	2	0
Management:	0	0
Control:	0	0

	RECEIVE	TRANSMIT
MSDU:	2	4018
Data:	2	4140
Multicast:	2	0
Errors:	0	487

Below the statistics are sections for 'DETAILED RECEIVE ERRORS' and 'DETAILED TRANSMIT ERRORS'. A 'Back' button is circled in red at the bottom left of the window.

- ❑ Click the Back button to return to the Main Status window.

- Step 7** In the left window pane, click the **Configuration** menu **Basic** option. The Basic Configuration window is displayed.

The screenshot shows the 'BASIC CONFIGURATION' window. The sidebar on the left has 'Configuration' expanded to show 'Basic' and 'SNMP'. The main content area is titled 'BASIC CONFIGURATION' and contains the following settings:

- System Name: UNIT A
- LAN section:
  - IP Address: 192.168.1.101
  - Subnet Mask: 255.255.255.0
  - Default Gateway: 0.0.0.0
- WIRELESS section:
  - Radio Spectrum Bandwidth: Normal
  - Radio Frequency (MHz): 5500
  - Data Rate (Mbps): 36

Buttons for 'Update', 'Reset', and 'Select' are visible at the bottom.

The maximum radio data rates listed below:

- ❑ United States – 72 Mbps
- ❑ European – 36 Mbps

**Step 8** As required by the customer, change the following settings on both the root and peer radios (see Table 2-1 or Figure 2-4).

- System Name
- IP Address and Subnet Mask (Default Gateway not required)
- Radio Frequency (May differ depending on the country of operation)

If you change any settings, click the **Update** button and reboot the system.

**Note:** After changing the IP address of the radio, it takes a moment for the RF unit to get settled.

**Step 9** Click the **Management** menu **Peer Unit's Info** option. The Peer Unit's Information window is displayed.

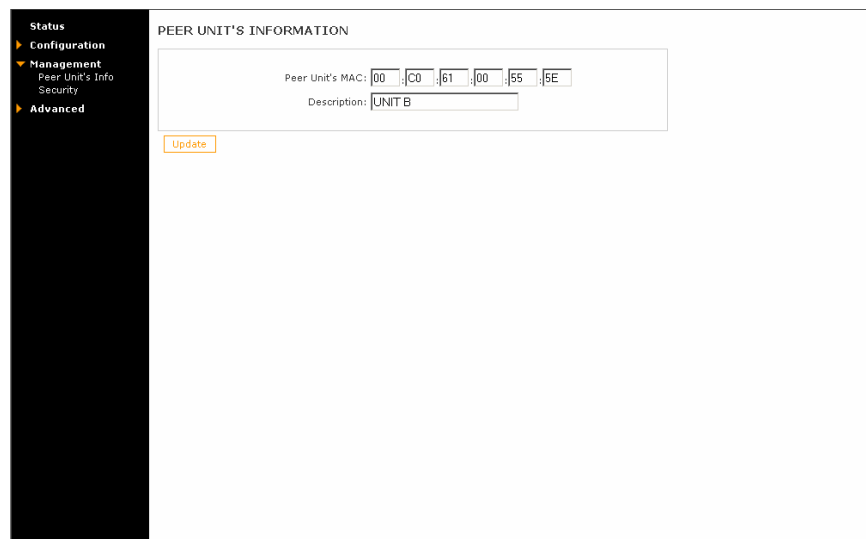

**Step 10** Each Root radio is programmed with the MAC address of its peer radio.

**Note:** Description can be left blank.

- Step 11** To set the encryption option, click the **Management** menu **Security** option. The Security Manager window is displayed.

The screenshot shows the SECURITY MANAGER interface. On the left is a navigation menu with 'Status', 'Configuration', 'Management', 'Peer Unit's Info', 'Security', and 'Advanced'. The 'Security' option is selected. The main area is titled 'SECURITY MANAGER' and contains an 'ENCRYPTION' section. It has three radio buttons: 'WEP', 'AES', and 'Clear'. The 'AES' radio button is selected. Next to 'WEP' is a dropdown for 'WEP Key Length' set to '64 bit/10 hex Digits' and a text field for 'WEP Key Value'. Next to 'AES' is a dropdown for 'AES Key Length' set to '152 bit/32 hex Digits' and a text field for 'AES Key Value' containing 32 'a' characters. At the bottom are 'Submit' and 'Reset' buttons.

- Step 12** Click on the AES button to enable AES encryption.

**Note:** If the AES radio button is selected, the AES Key Value field must be populated with something. In the above example the field has been populated with a's.

- Step 13** To configure the radios to use SNMP (Simple Network Management Protocol), click the **Configuration** menu **SNMP** option. The SNMP Configuration window is displayed.

The screenshot shows the SNMP CONFIGURATION interface. On the left is a navigation menu with 'Status', 'Configuration', 'Basic', 'SNMP', 'Management', and 'Advanced'. The 'SNMP' option is selected. The main area is titled 'SNMP CONFIGURATION' and contains four text input fields: 'Get Community Name' (public), 'Set Community Name' (private), 'Trap Community Name' (default), and 'Trap Manager IP Address' (0.0.0.0). At the bottom are 'Update' and 'Reset' buttons.

- Step 14** Enter the customer supplied Community Names and Trap Manager IP Address information. Click the **Update** button to activate changes.

- Step 15** Reboot the radios to save changes. Click the **Advanced** menu **Reboot** option. The System Reboot window is displayed.

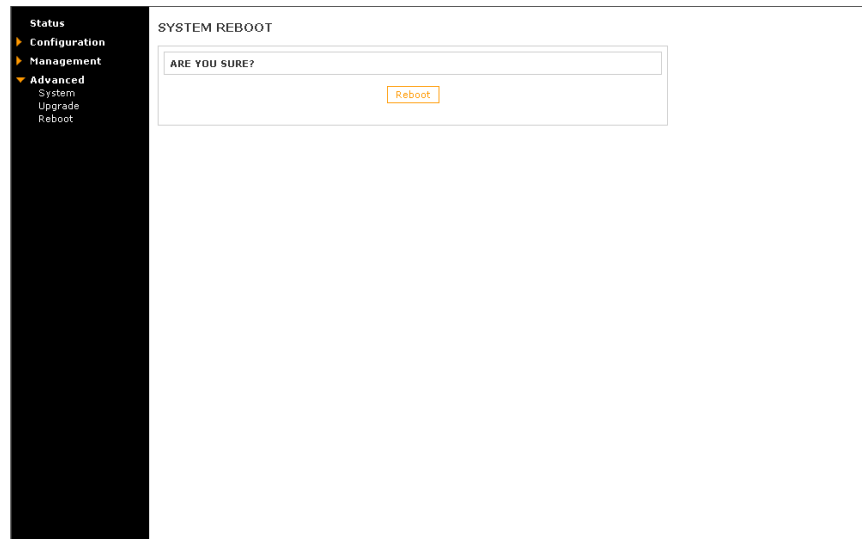

- Step 16** Click on the **Reboot** button to reboot the radios.

**Note:** It takes much longer than 30 seconds for the radios to reboot.

- Step 17** Disconnect the crossover cable and reconnect the unit as shown in Figure 2-4.

## Optical Linkhead Configuration using a Crossover Cable

As required by system configuration (refer to Table 2-1), the factory default linkhead configuration settings can be changed using the following procedure.

**Important Note:** The FSA 100 XA system components (linkheads, switches and radios) have been customized and preconfigured to ensure optimal performance in LightPointe-specific Optical Wireless installations. Any changes to default settings, port assignments, use of advanced switch features or use of non-LightPointe linkheads or radios may impact system operation and will not be supported by LightPointe.

**Step 1** Connect a crossover ethernet cable between the linkhead management ethernet port and the ethernet port on a PC.

**Note:** The PC management console IP Addresses must be set to the addresses shown in Table 2-1.

**Step 2** Start up a Browser program on the PC.

- ❑ The linkheads can be configured using a web browser such as Netscape® Navigator (version 6.2 and higher) or Microsoft® Internet Explorer (version 5.0 and higher)

**Step 3** To access the linkhead, at the browser URL address line enter the appropriate linkhead default IP address (see Table 2-1, Table 2-2 or Figure 2-4). The Main FlightManager XA window is displayed.

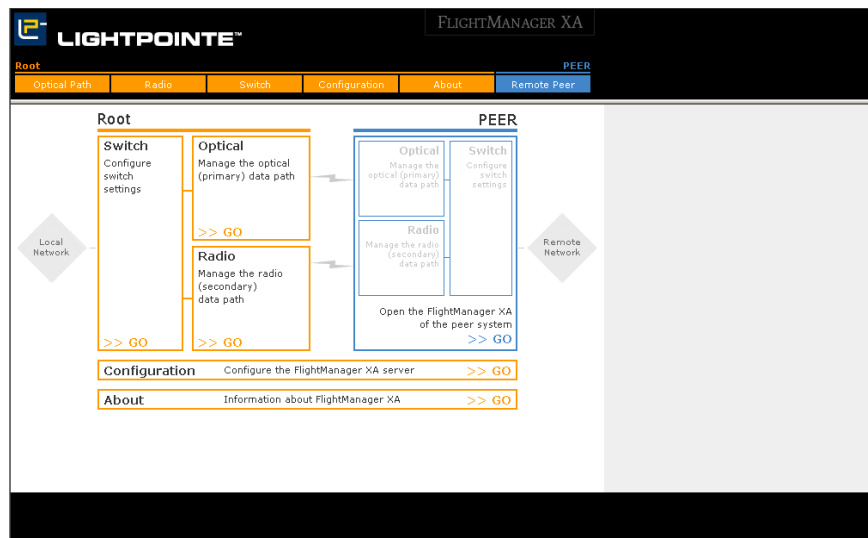

- Step 4** Click on the Configuration option **GO** button. The Configuration window is displayed.

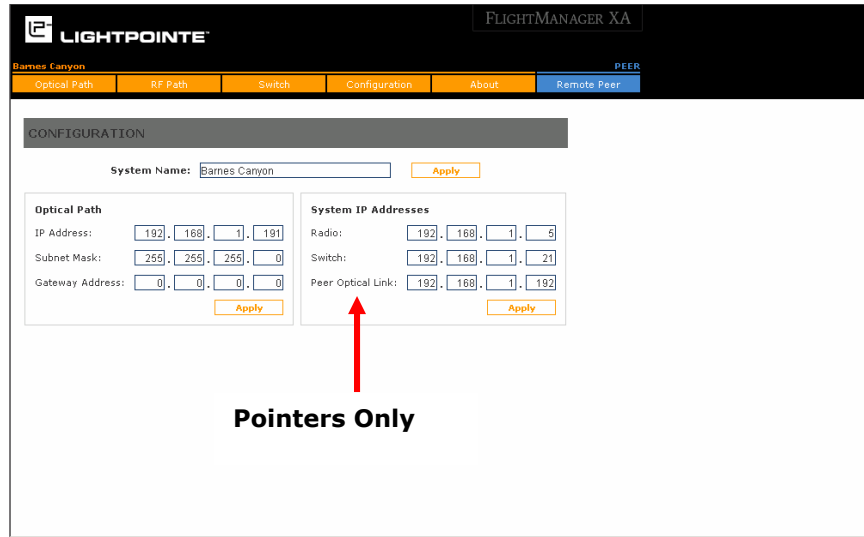

- Step 5** Enter the new customer specified linkhead IP address.
- Step 6** In the System IP Addresses box enter the pointer addresses for the radio, switch and peer optical link.
- Note:** These changes have no effect on the switch, radio or peer linkhead.
- Step 7** Disconnect the PC cable and reconnect the unit as shown in Figure 2-4.

### 2.6.3. Hardware Configuration after Installation using the FlightManager XA GUI

After the hardware is installed, the switch, radio, and linkhead configuration settings can be updated as required.

**Note:** FlightManager XA only supports one connection at a time. Do not open FlightManager XA browser sessions from multiple computers.

**Important Note:** The FSA 100 XA system components (linkheads, switches and radios) have been customized and preconfigured to ensure optimal performance in LightPointe-specific Optical Wireless installations. Any changes to default settings, port assignments, use of advanced switch features or use of non-LightPointe linkheads or radios may impact system operation and will not be supported by LightPointe.

#### PC Web Browser Connection

**Step 1** Ensure the system is interconnected as shown in Figure 2-4. Double check switch port usage:

- Port #1 – Connected to a PC or Laptop
- Port #22 – Linkhead Data (STP enabled)
- Port #23 –Linkhead Management
- Port #24 – RF Unit (STP Enabled)

**Step 2** Connect an ethernet cable between port 1 and the ethernet port on a PC.

**Note:** The PC management console IP Addresses must be set to the addresses shown in Table 2-1.

**Step 3** Start up a Browser program on the PC.

- The linkheads can be configured using a web browser such as Netscape® Navigator (version 6.2 and higher) or Microsoft® Internet Explorer (version 5.0 and higher)

**Step 4** To access the FlightManager XA window, at the browser URL address line enter the appropriate linkhead default IP address (see Table 2-1, Table 2-2 or Figure 2-4). The Main FlightManager XA window is displayed.

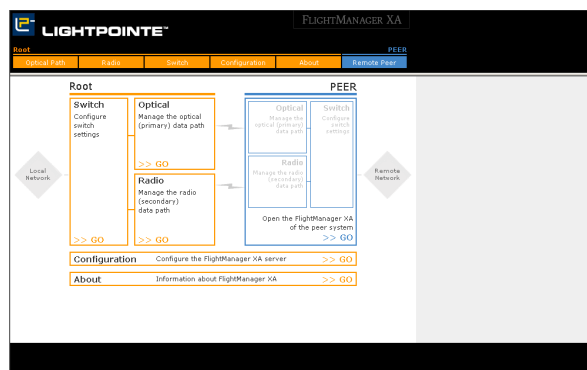

## Switch Configuration using a Web Browser

The Web-based management module and the RS-232 CLI Console program are different ways to access the same internal switching software and configure it. All settings encountered in web-based configuration are the same as those found in the CLI console program (see section 2.6.2).

**Important Note:** The FSA 100 XA system components (linkheads, switches and radios) have been customized and preconfigured to ensure optimal performance in LightPointe-specific Optical Wireless installations. Any changes to default settings, port assignments, use of advanced switch features or use of non-LightPointe linkheads or radios may impact system operation and will not be supported by LightPointe.

**Note:** FlightManager XA only supports one connection at a time. Do not open FlightManager XA browser sessions from multiple computers.

**Step 1** To open the switch Web window from the Main FlightManager XA window, click on the Switch GO button. The Switch Information window is displayed.

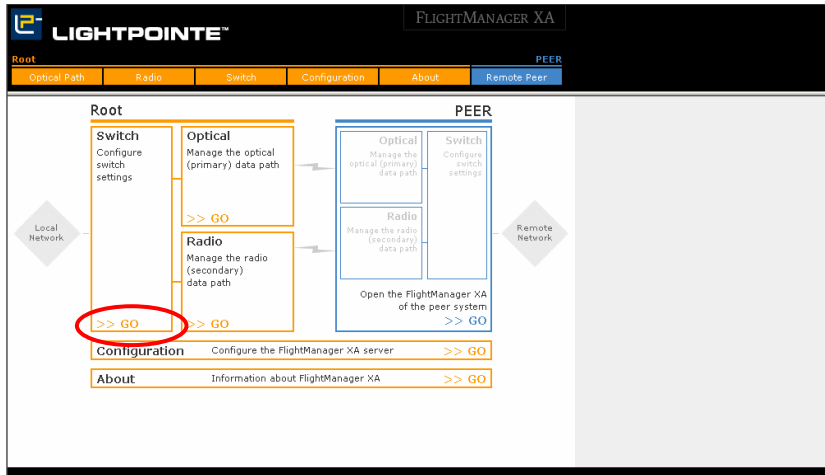

- Step 2** The Switch Information screen displays the Switch's MAC Address (assigned by the factory and unchangeable), IP configuration, important settings and status information.

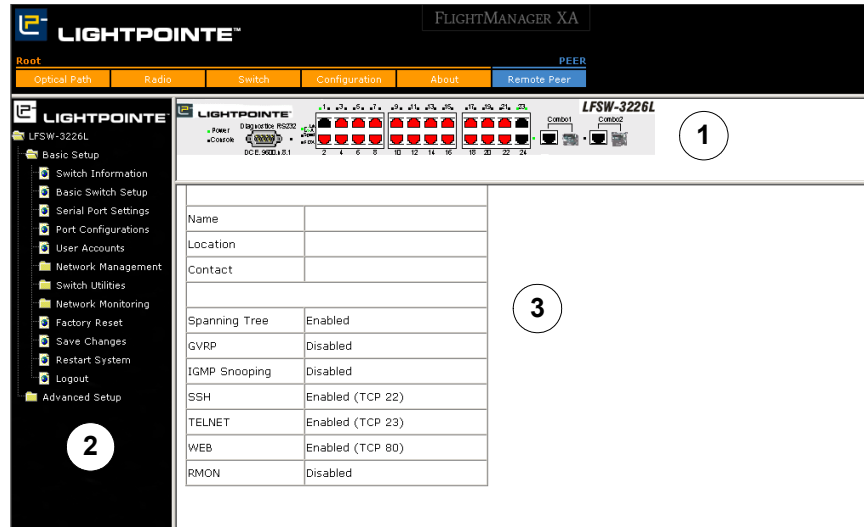

- ❑ Pane 1 presents a graphical image of the front panel of the Switch.
- ❑ Pane 2 is used to select the window to be displayed.
- ❑ Pane 3 Displays switch information based on your selection in Area 2.

- Step 3** Click the **Basic Setup** option in the menu window pane on the left side. The Basic Switch Setup information is displayed.

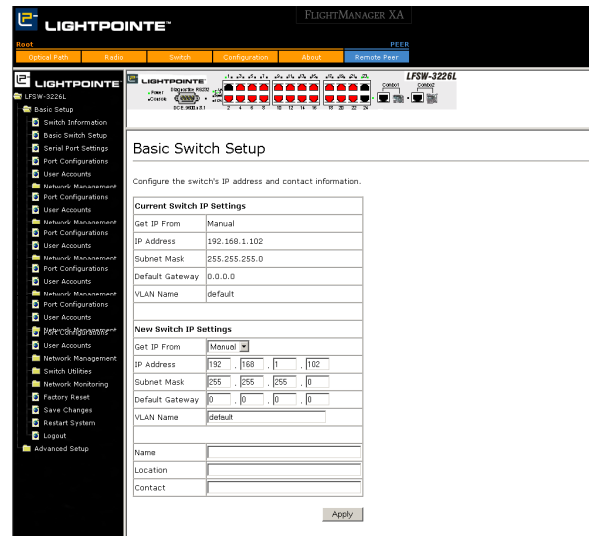

- ❑ In the **Get IP From** drop-down menu, select **Manual**.
- ❑ Enter the appropriate IP address and subnet mask (see Table 2-1 or Figure 2-4).

**Note:** You must use the procedures in Section 2.6.2 if you decide to change the IP Addresses to a new Subnet.

- ❑ Click on the **Apply** button to save changes.

- Step 4** Click the **Serial Port Settings** option. The Serial Port Settings window is displayed.

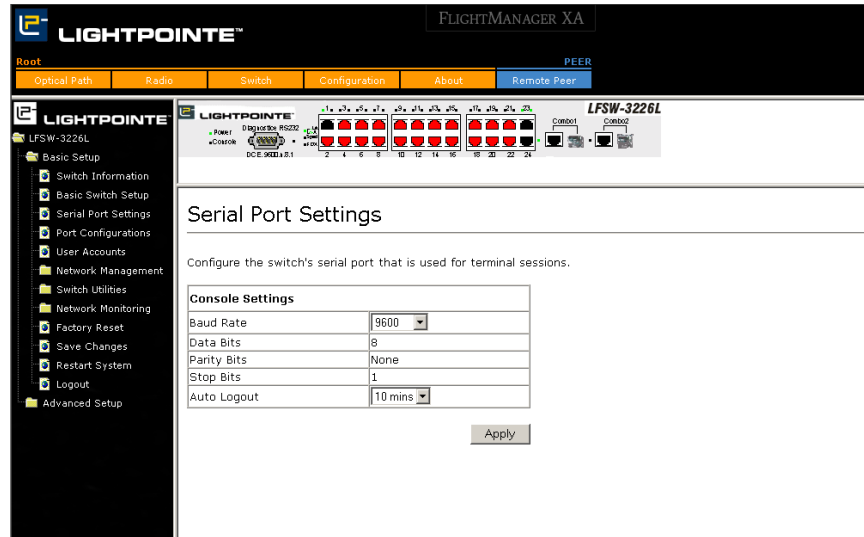

- Use factory default settings shown above

- Step 5** Click the **Port Configuration** option. The Port Configuration window is displayed.

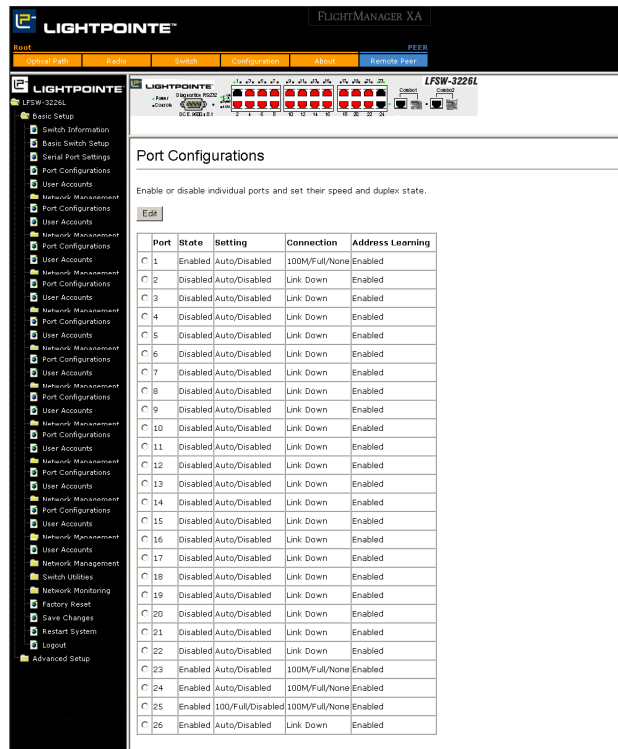

Use the factory default settings.

- Ports 2-21, 25 and 26 state disable
- Port 22 speed 100\_full

- Step 6** Click on **Advanced Setup, Spanning Tree**, select the **STP Switch Settings** option. The STP Switch Settings window is displayed.

The screenshot shows the LIGHTPOINTE FLIGHTMANAGER XA interface. The main window is titled "STP Switch Settings" and contains the following configuration fields:

Status	Enabled	Designated Root Bridge	00-0F-3D-EB-4B-C2
Max Age (6 - 40 sec)	6	Root Priority	4096
Hello Time (1 - 10 sec)	1	Cost to Root	0
Forward Delay (4 - 30 sec)	4	Root Port	None
Priority (0 - 61440)	4096	Last Topology Change	2103 secs.
Default Path Cost	802.1T	Topology Changes Count	7
STP Version	RSTP	Protocol Specification	3
TX Hold Count (1-10)	10	Max Age	6
Forwarding BPDU	Disable	Hello Time	1
		Forward Delay	4
		Hold Time	10

Below the table, there is an "Apply" button and a note: "The above values must conform to this formula:  $2 * (\text{Hello Time} + 1) \leq \text{Max Age} \leq 2 * (\text{Forward Delay} - 1)$ ".

Use the factory default settings shown above.

- Root Priority set to 4096
- Peer Priority set to 8192

**Step 7** Click the **STP Port Table** option. The STP Port Table window is displayed.

The screenshot shows the LIGHTPOINTE FLIGHTMANAGER XA interface. The left sidebar contains a navigation tree with 'STP Port Settings' selected under 'Advanced Setup'. The main window displays the 'STP Port Table' configuration for device LFSW-3226L. An 'Edit' button is visible above the table.

Port	Connection	State	Cost	Pri	Edge	P2P	Status	Role
C 1	100M/Full/None	Yes	*200000	128	Yes	Yes	Forwarding	Designated
C 2	Link Down	Yes	*200000	128	No	Yes	Disabled	Disabled
C 3	Link Down	Yes	*200000	128	No	Yes	Disabled	Disabled
C 4	Link Down	Yes	*200000	128	No	Yes	Disabled	Disabled
C 5	Link Down	Yes	*200000	128	No	Yes	Disabled	Disabled
C 6	Link Down	Yes	*200000	128	No	Yes	Disabled	Disabled
C 7	Link Down	Yes	*200000	128	No	Yes	Disabled	Disabled
C 8	Link Down	Yes	*200000	128	No	Yes	Disabled	Disabled
C 9	Link Down	Yes	*200000	128	No	Yes	Disabled	Disabled
C 10	Link Down	Yes	*200000	128	No	Yes	Disabled	Disabled
C 11	Link Down	Yes	*200000	128	No	Yes	Disabled	Disabled
C 12	Link Down	Yes	*200000	128	No	Yes	Disabled	Disabled
C 13	Link Down	Yes	*200000	128	No	Yes	Disabled	Disabled
C 14	Link Down	Yes	*200000	128	No	Yes	Disabled	Disabled
C 15	Link Down	Yes	*200000	128	No	Yes	Disabled	Disabled
C 16	Link Down	Yes	*200000	128	No	Yes	Disabled	Disabled
C 17	Link Down	Yes	*200000	128	No	Yes	Disabled	Disabled
C 18	Link Down	Yes	*200000	128	No	Yes	Disabled	Disabled
C 19	Link Down	Yes	*200000	128	No	Yes	Disabled	Disabled
C 20	Link Down	Yes	*200000	128	No	Yes	Disabled	Disabled
C 21	Link Down	Yes	*200000	128	No	Yes	Disabled	Disabled
C 22	Link Down	Yes	*200000	128	No	Yes	Disabled	Disabled
C 23	100M/Full/None	Yes	*200000	128	Yes	Yes	Forwarding	Designated
C 24	100M/Full/None	Yes	*200000	128	No	Yes	Forwarding	Designated
C 25	100M/Full/None	Yes	*200000	16	No	Yes	Forwarding	Designated
C 26	Link Down	No	*20000	128	No	Yes	Disabled	Disabled

Use the factory default settings shown above.

- Port 22 priority set to 16
- Port 26 state disabled

- Step 8** Click on **Advanced Setup, Configure QOS**, select the **Bandwidth Control Table** option. The Bandwidth Control Table window is displayed.

The screenshot shows the FlightManager XA interface for a LIGHTPOINT LFSW-3226L switch. The 'Configuration' tab is active, and the 'Bandwidth Control Table' window is open. The table below shows the factory default settings for each port.

Port	RX Rate (100Kbps)	TX Rate (100Kbps)
1	No Limit	No Limit
2	No Limit	No Limit
3	No Limit	No Limit
4	No Limit	No Limit
5	No Limit	No Limit
6	No Limit	No Limit
7	No Limit	No Limit
8	No Limit	No Limit
9	No Limit	No Limit
10	No Limit	No Limit
11	No Limit	No Limit
12	No Limit	No Limit
13	No Limit	No Limit
14	No Limit	No Limit
15	No Limit	No Limit
16	No Limit	No Limit
17	No Limit	No Limit
18	No Limit	No Limit
19	No Limit	No Limit
20	No Limit	No Limit
21	No Limit	No Limit
22	No Limit	No Limit
23	No Limit	No Limit
24	No Limit	192

Use the factory default settings shown above.

- Port 24 TX Rate set to 192

**Note:** Any changes made to the Switch configuration during the current session must be saved in the **Save Changes** window.

- Step 9** To return to the FlightManager XA window, click on the LightPointe logo at the upper left corner of the window. The main FlightManager XA window is displayed.

**Step 10** To configure the Peer Switch, click on the Peer **GO** button. The Switch **GO** buttons on the left side of the Window can now be used to access the Peer Switch.

**Note:** FlightManager XA only supports one connection at a time. Do not open FlightManager XA browser sessions from multiple computers.

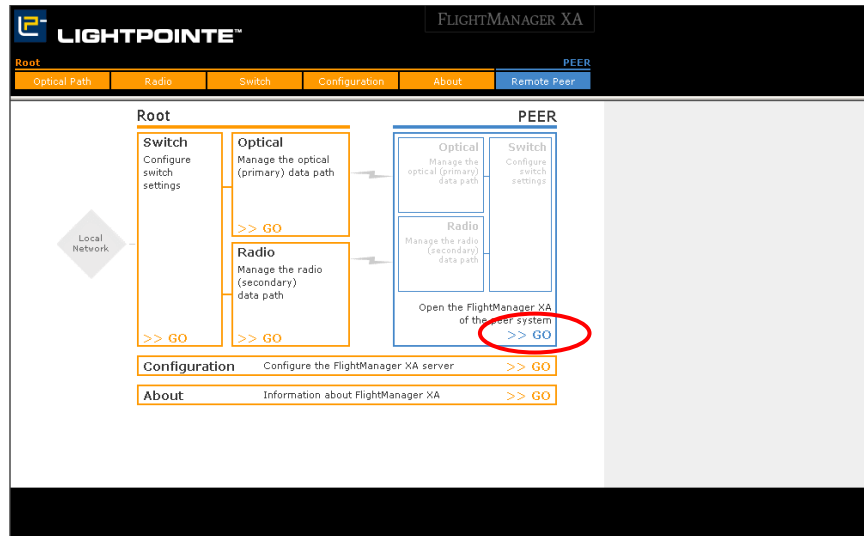

## Radio Configuration using a Web Browser

Radio configuration windows are accessed by using the software. All settings encountered in web-based configuration are the same as those found in Section 2.6.2.

**Note:** FlightManager XA only supports one connection at a time. Do not open FlightManager XA browser sessions from multiple computers.

- Step 1** To open the Root Radio Web window from the Main FlightManager XA window, click on the Root Radio **GO** button. The Radio Main Status window is displayed.

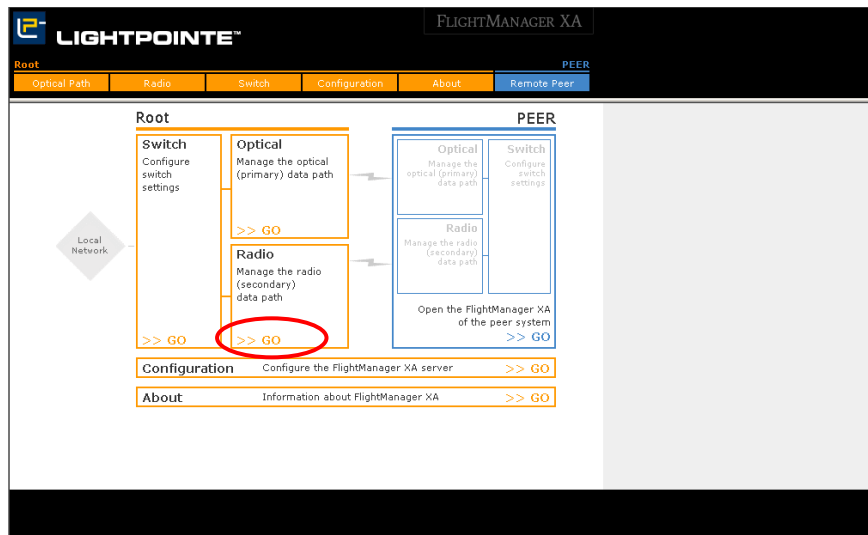

- Step 2** The radio configuration procedures performed at this point are identical to the procedures found on page 2-18, starting at Step 5.

**Note:** You must use the procedures in Section 2.6.2 if you decide to change the IP Addresses to a new Subnet.

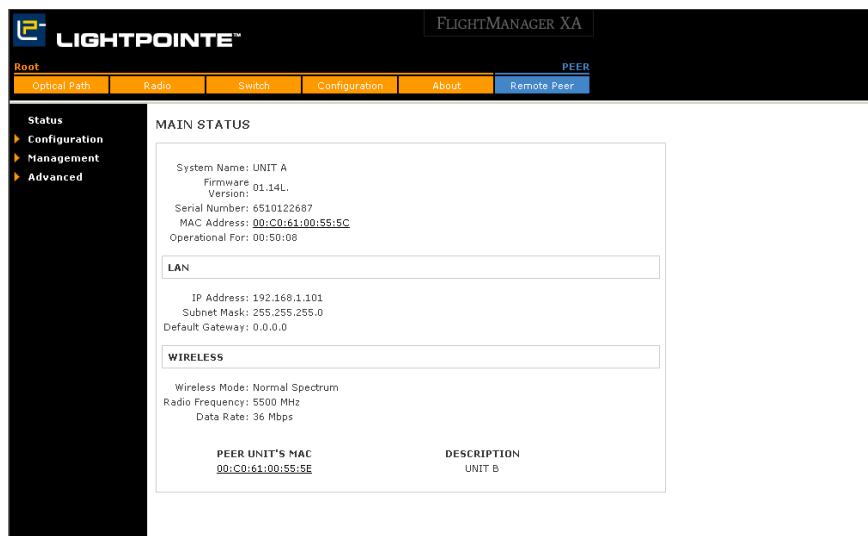

**Step 3** To return to the FlightManager XA window, click on the LightPointe logo at the upper left corner of the window. The main FlightManager XA window is displayed.

**Step 4** To configure the Peer Radio, click on the Peer **GO** button. The Radio **GO** buttons on the left side of the Window can now be used to access the Peer radio.

**Note:** FlightManager XA only supports one connection at a time. Do not open FlightManager XA browser sessions from multiple computers.

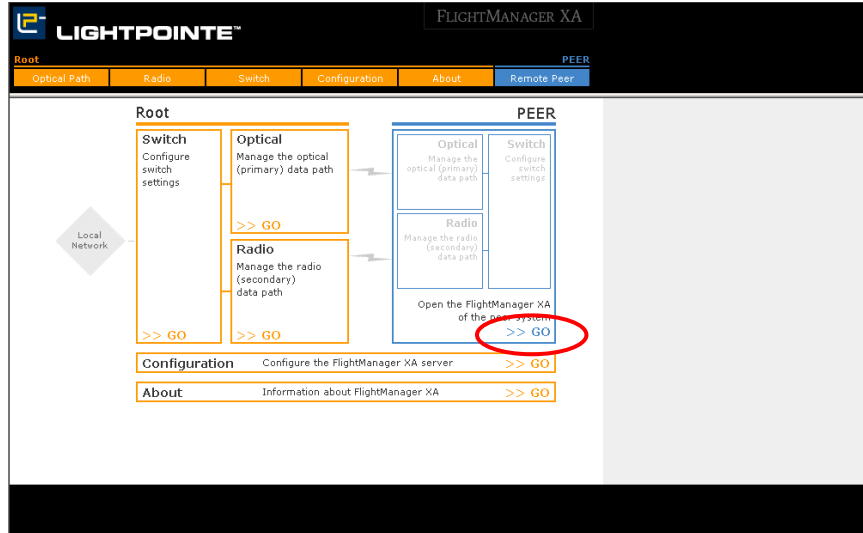

## Linkhead Configuration using a Web Browser

The only configuration parameter that you may need to change is the linkhead IP address.

**Note:** FlightManager XA only supports one connection at a time. Do not open FlightManager XA browser sessions from multiple computers.

- Step 1** To change the FlightManager XA IP address, click on the Configuration **GO** button. The Linkhead Configuration window is displayed.

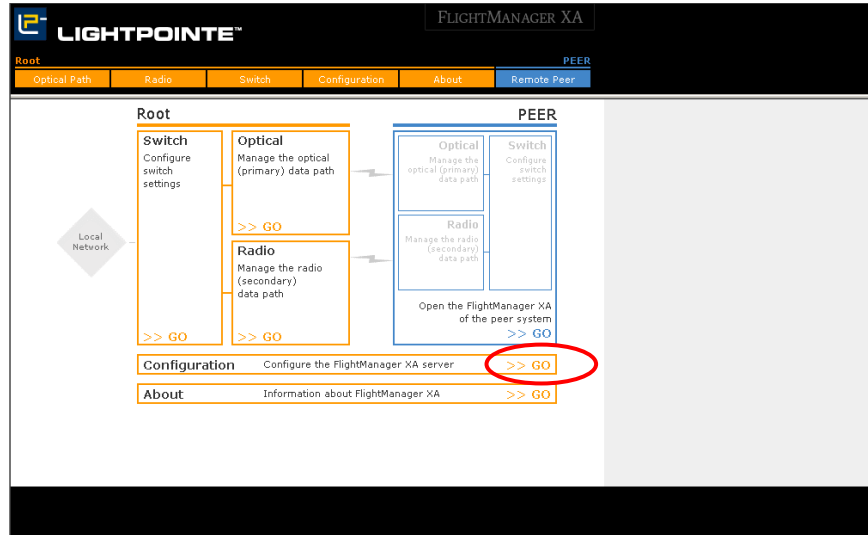

- Step 2** Enter the new customer specified linkhead IP address information.

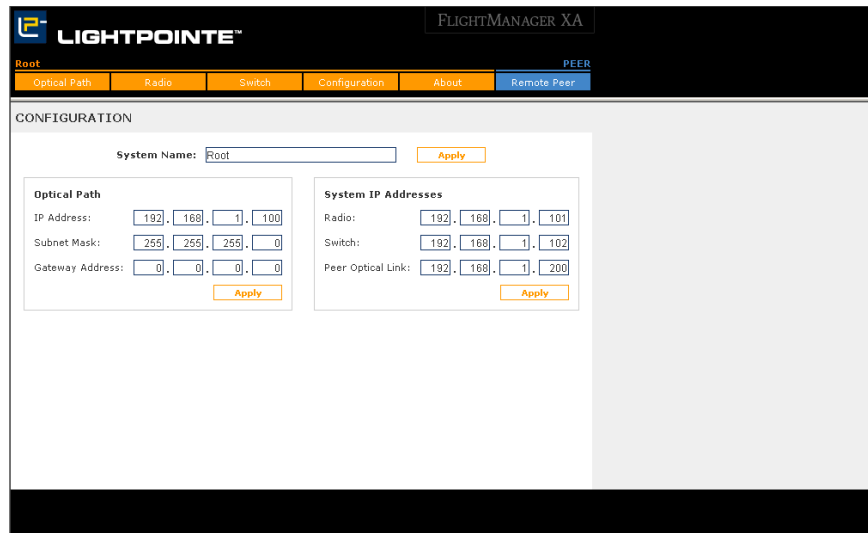

**Note:** You must use the procedures in Section 2.6.2 if you decide to change the IP Addresses to a new Subnet.

**Step 3** To return to the FlightManager XA window, click on the **LightPointe** logo at the upper left corner of the window. The main FlightManager XA window is displayed.

**Step 4** To configure the Peer linkhead, click on the Peer **GO** button. The Optical GO buttons on the left side of the Window can now be used to access the Peer Linkhead.

**Note:** FlightManager XA only supports one connection at a time. Do not open FlightManager XA browser sessions from multiple computers.

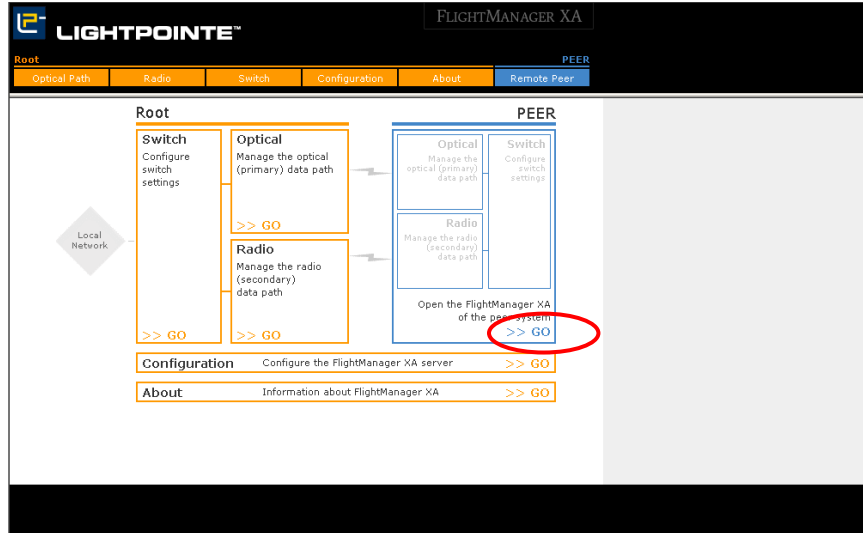

## 2.7. Optical and RF Installation Components

### 2.7.1. Linkhead Optical Components

#### Universal Mount Hardware

The universal mount is used for pedestal or wall mounting the linkhead.

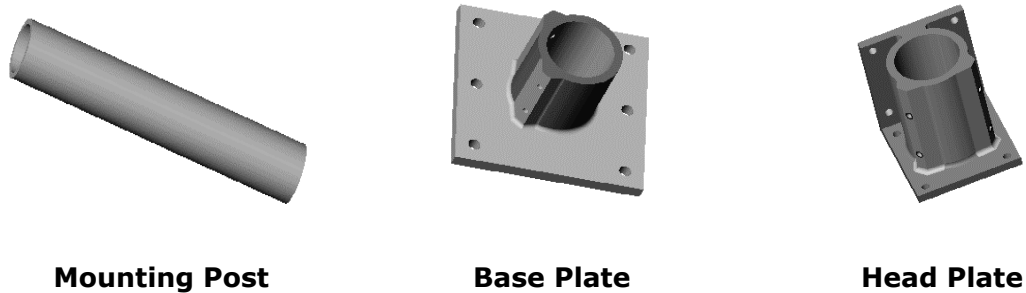

**Figure 2-5: Universal Mount Hardware**

#### Pan and Tilt Hardware

The pan and tilt assembly and hardware is used for initial coarse alignment and final fine alignment of the linkheads for maximum receive power. The Pan and Tilt is specially engineered to provide the stability and strength required by Free Space Optics systems to provide trouble free performance.

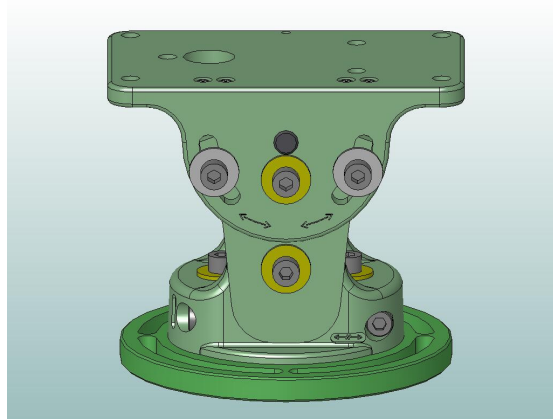

**Figure 2-6: Pan and Tilt Hardware**

## Power Supply Assembly

The weatherproof power supply assembly should be mounted near the linkhead.

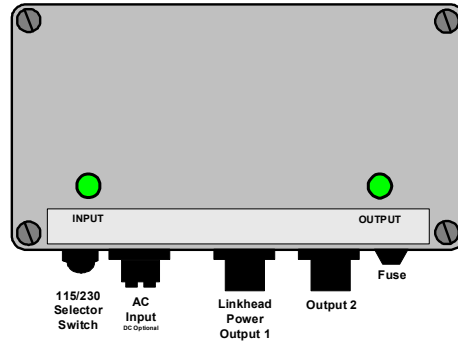

**Figure 2-7: Power Supply Assembly**

This assembly includes:

- ❑ universal AC power input (requires correct switch setting on power supply)
- ❑ A 90 – 240 VAC 50/60 Hz power input (requires correct user option-switch setting)
- ❑ Dual 48 VDC power outputs to power one or two linkheads with a single power supply
- ❑ External connectors for power input and output
- ❑ Ability to power one or two linkheads with a single power supply
- ❑ Ability to provide redundant power with two power supplies interconnected
- ❑ Input and output power LED indicators
- ❑ Redundant load sharing power supplies may be configured for maximum reliability by ordering the “Y” cable described below

### FlightPower Options

The available power supply options are listed in Table 2-3.

**Table 2-3: FlightPower Options**

Power Supply	Description
LPC-A48	Standard 90 – 240 VAC 50/60 Hz Power Supply
LPS-00-I	Spare AC input cord from power source
LPC-00-O	Spare DC output cord to linkhead
LPC-00-Y	Y Cable to allow two power supplies to be configured feeding one linkhead in a redundant load sharing configuration

## Linkhead Assembly

The linkhead and pan and tilt hardware are mounted on the head plate assembly.



**Figure 2-8: Linkhead and Pan and Tilt Assemblies**

The linkhead assembly consists of:

- ❑ A linkhead cover
- ❑ Optics, transmission, and receiver assembly
- ❑ An alignment telescope
- ❑ Interface back panel
- ❑ Internal fiber connectors
- ❑ External power and conduit connectors

## 2.7.2. RF Components

### RF Mounting Kit Assembly

The two-way mounting kit is used for connecting the RF antenna to a mounting post (typically, the same post as the linkhead). There are three possible mount configurations to accommodate small, medium and large mast diameters.

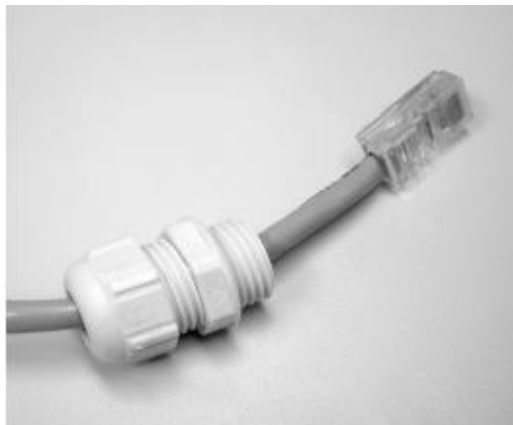

**Figure 2-9: RF Mounting Clamps**

### Ethernet Cables

An outdoor rated CAT-5 Ethernet cable is needed to connect the RF antenna to the indoor POE injector. An additional straight CAT-5 cable is required to connect from the POE injector to the switch. The combined length of the two CAT-5 cables must not exceed 200 feet.

To ensure all-weather operation, a weatherproofing cable gland must be built into the Ethernet cable. The seal can be slipped onto the CAT-5 cable before attaching the RJ45 connectors at the ends.



**Figure 2-10: Waterproof Cabling Gland**

## Power-Over-Ethernet (POE) Injector

An indoor POE injector provides power to the antenna/radio via a CAT-5 Ethernet cable.



**Figure 2-11: Power-Over-Ethernet (POE) Injector**

## Antenna and Radio

The RF panel antenna and radio are fully integrated into a weatherproof chassis for simple operation.



**Figure 2-12: Antenna and Radio**

## 2.8. Assemble and Mount System Equipment

### 2.8.1. Optical Equipment

The following steps must be followed to setup the optical equipment.



**Caution:** For indoor installations where people may be present, the linkhead(s) should be installed close enough to the window to prohibit looking into the transmitter beams. Avoid linkhead angles of 45 degrees and greater perpendicular to the window glass.

**Step 1** Install the mounting base plate to a solid platform using 12 mm (1/2") screws.

- Anchor the mount in wall or concrete (recommend M12-screws)
- Use bolts of property class 6.6 or better

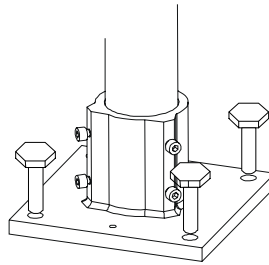

- Use the base plate as a template to aligning any penetration holes

**Step 2** Attach and fasten the mounting post assembly to the installed base plate using the supplied set screws. Tighten the set screws snugly with the hex wrench supplied.

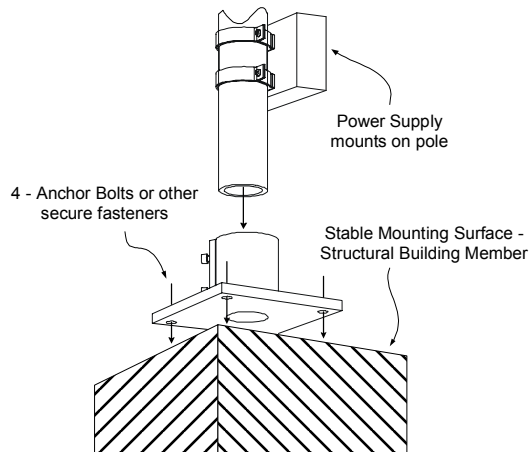

To ensure stability, keep the mounting post as short as possible. Remember to leave enough room for mounting the RF antenna.

**Note:** The maximum allowable mounting pole length is 70 cm (27.5").

- Step 3** Mount the linkhead and Pan and Tilt assembly to the Head Plate using the hardware supplied by LightPointe.

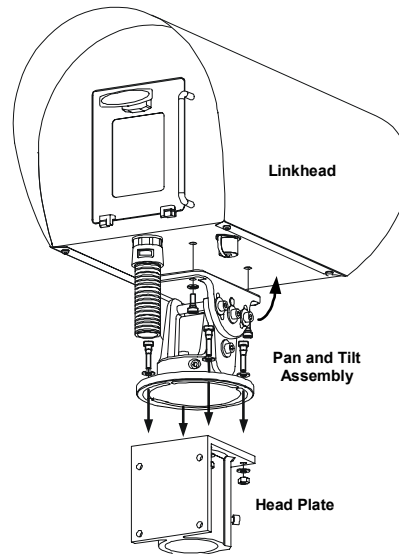

- Step 4** Place the linkhead (with pan and tilt and head plate assembled) onto the mounting pole. It is much easier to assemble these components and then place them onto the pole as a unit. This is especially recommended in dangerous locations such as towers or high buildings.

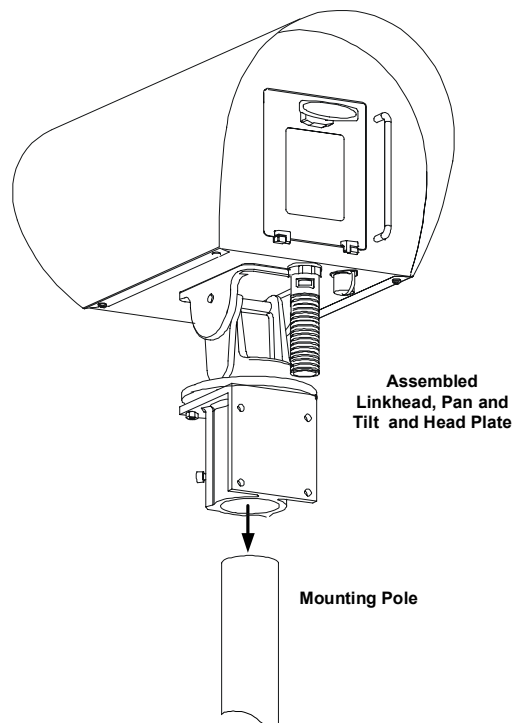



**Caution:** The base plate and head plate must be pinned to the mounting post when the base plate is wall mounted.

**Step 5** To pin the base plate and head plate to the mounting post when used in a horizontal mount:

- ❑ Drill an 8 mm hole through the cylinder wall of the base plate and the mounting post and pin the assemblies together using 8 mm grooved pins or 3/8 x 1 inch screws.
- ❑ Drill an 8 mm hole through the cylinder wall of the head plate and the mounting post and pin the assemblies together using 8 mm grooved compression fit pins or 3/8 x 1 inch stainless steel screws.
- ❑ Position the pins at the opposite side of the cap and base from the tensioning screws. This will assure that the mount does not rotate and cause system misalignment.

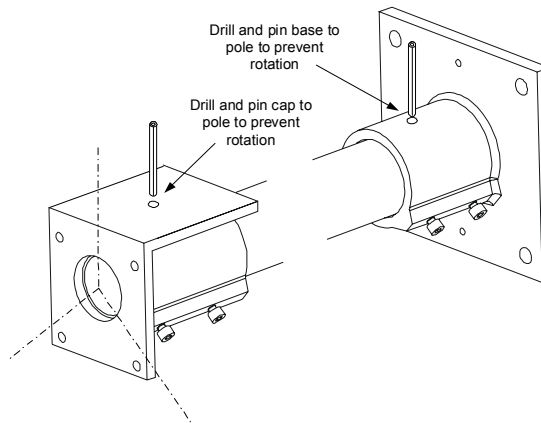

**Step 6** Mount the power supply to the Mounting Pole using the hardware supplied with the power supply assembly. The following illustration shows the power supply in a typical position. There are other ways to mount the power supply. These options are explained in the following section.

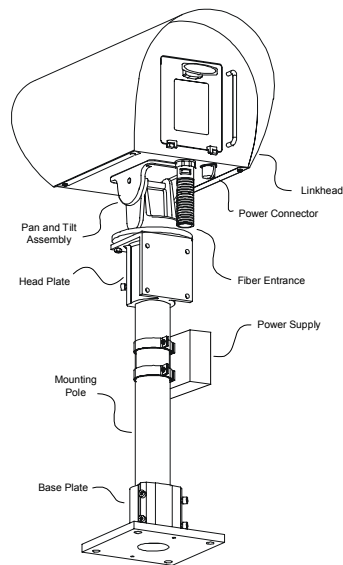

## 2.9. Assemble and Mount the Power Supply

The following steps must be followed to setup the optical equipment.

- Step 1** If the power supply will be used with the standard LightPointe universal mount, use the two round, insulated clamps provided with the power supply to attach the unit to the pole.

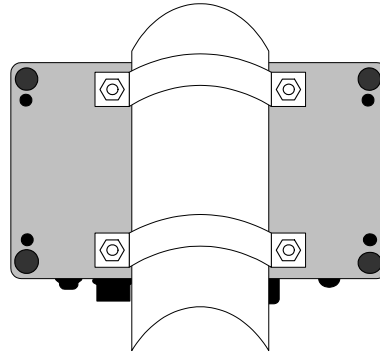

- Step 2** If the power supply will be mounted with the pole in a horizontal position, turn the back plate by removing the four sets of nuts, rotating the plate and then re-securing the back plate.

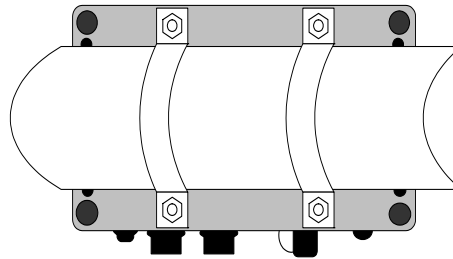

If the power supply is to be mounted to a surface other than the standard LightPointe pole, the power supply may be secured using the two metal brackets provided with the system. The mounting brackets are secured to the power supply as indicated, and the system should then be attached to a solid surface with the appropriate type of mounting screws.

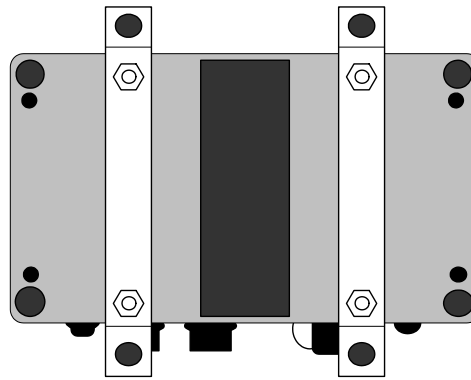

Wall Mount Brackets  
may be attached using  
standard mounting posts  
on rear of unit

**Note:** The maximum recommended distance between the power supply box and the linkhead is 3 meters.



**Caution:** Disconnect main power before connecting electrical cables.

**Step 3**

There is a 3-meter power cord provided with the standard AC power supply. The connector on the cord is pre-wired, and the cord tail provides three labeled wires (Hot, Neutral and Ground) that must be properly terminated (junction box, electrical plug, etc.) for connection to an electrical power source. LightPointe recommends that the power cord be hard-wired into a dedicated and surge protected circuit.

Once the power cord is properly connected to an electrical source, the power cord connector can be plugged into the AC Input connector on the power supply.



**Warning:** Ensure that the correct power cable is used. Exercise extreme caution when terminating the wires into the connector!

Incorrect wiring at the connector can injure people and cause fire hazards and may cause damage to the equipment that is NOT covered under warranty!

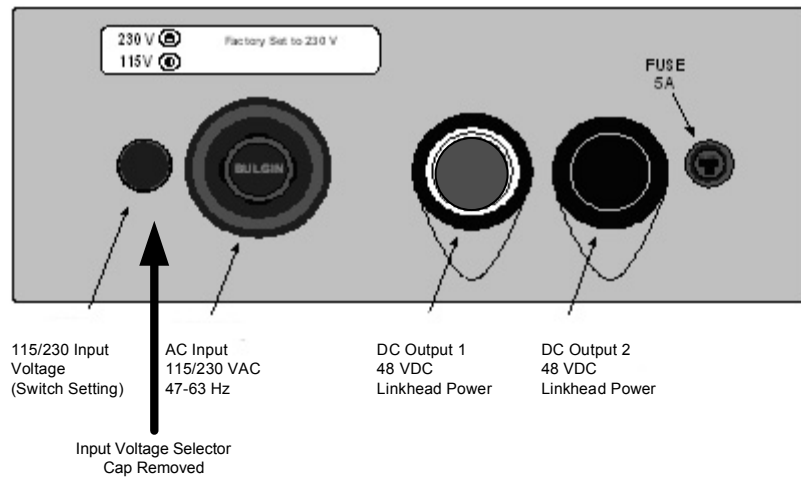

- Step 4** Set the power supply input selector switch to the correct position. The power supply is preset at the factory to an input voltage of 230 VAC. To reset the input voltage to 115 VAC, remove the input selector switch cover protective cap, turn the selector switch to the vertical position and replace the protective cover.



**Caution:** Ensure that the correct power input voltage is selected before applying power to the power supply.

Do not set the power supply to 115 VAC and then apply 230 VAC – this will damage the power supply.

If the power supply is set to 230 VAC and then connected to 115 VAC, the output from the power supply will not be high enough to operate the linkhead.

The power supply input selector switch should NEVER be changed while power supply is connected to its primary power source.

If it is necessary to lengthen the power cord, another longer cord may be retrofit to the existing input connector. Open the power connector by removing the locking ring from the connector. The prongs on the caps of the protective cover of the cord can be used to remove the locking ring.

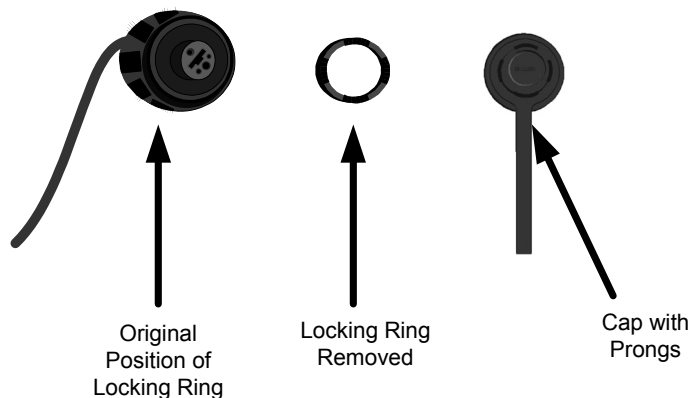

- Step 5** Loosen the strain relief on the connector to release the power cord and detach the power cord wires from the connector.

Place the strain relief over the new power cord, thread the power cord through the connector and connect the wires of the power cable to the correct pins of the terminal connector as indicated on the connector and in the following picture. The power cord cable outer sheath diameter must be between 5 and 10.25 mm (.19 to .38 inches) in diameter, and the individual wire connections at the connector plug must be between .75 mm<sup>2</sup> and 3.31 mm<sup>2</sup> (18 AWG to 12 AWG).

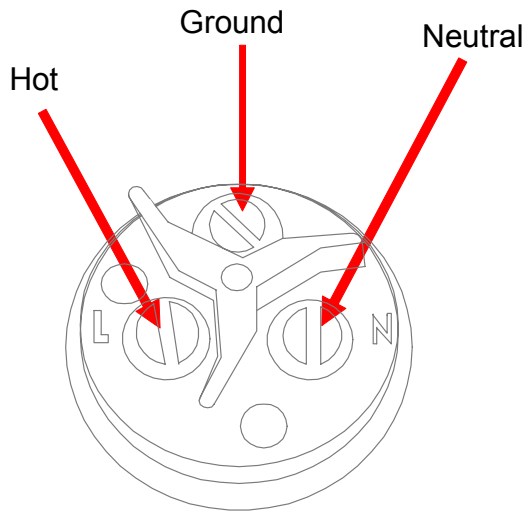

Once the wires have been connected, reassemble the input power connector. Ensure that the key slot on the terminal block is properly aligned with the key tab on the connector. Replace and tighten the locking ring, then connect the power cord to the AC Input connector.

- Step 6** Connect the 48 VDC cable to the bottom of the linkhead at the external connector plug receptacle.

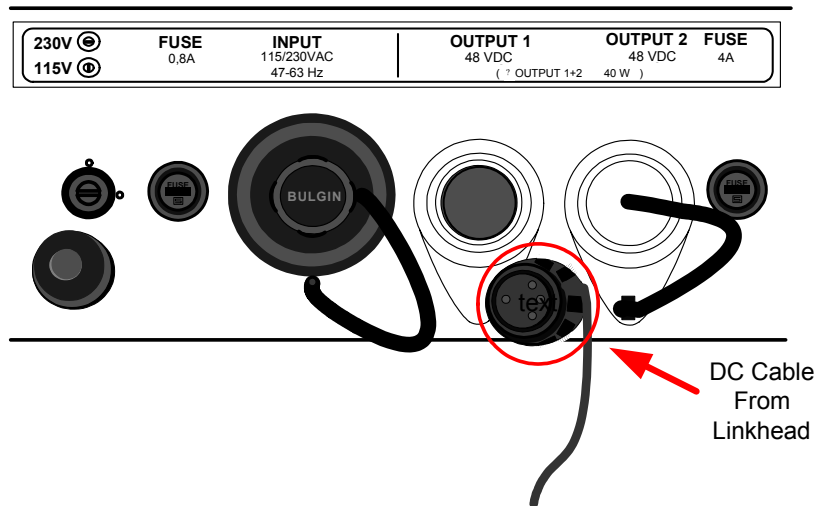

Connect the DC cable from the linkhead to the power supply (one 3 meter cord provided with each power supply) to the power supply by unscrewing the cap from the Output 1 port and securing the connector into the plug.

**Note:** The second power output port (Output 2) from the power supply can be used to connect to a second linkhead.

**Note:** If redundant power supplies are desired, a separate (back-up) power supply and cable to interconnect two power supplies may be ordered from LightPointe. The LPS-00-R "Y" Cable should be ordered.

**Step 7** Repeat these steps at the second linkhead.

**Step 8** Apply power to both linkheads by connecting the input power cable from its AC source into the Input connector on the power supply.

- ☐ Make sure that both the "Input" and "Output" indicator lights on the power supply are illuminated.

## 2.10. Test Mount Stability

LightPointe FSO systems are engineered to allow for a certain amount of movement in each of the three axes in which a link head can move under force. The three axes can be thought of as:

- ❑ Rocking back and forth
- ❑ Swaying from side to side
- ❑ Twisting

The twisting and rocking movements cause the most significant problem because they affect the angle of launch. Fortunately, these two movements are also the least likely to occur. Use only LightPointe mounts which are engineered to not twist or torque. The optical divergence of the linkhead is engineered to match LightPointe mount specifications.

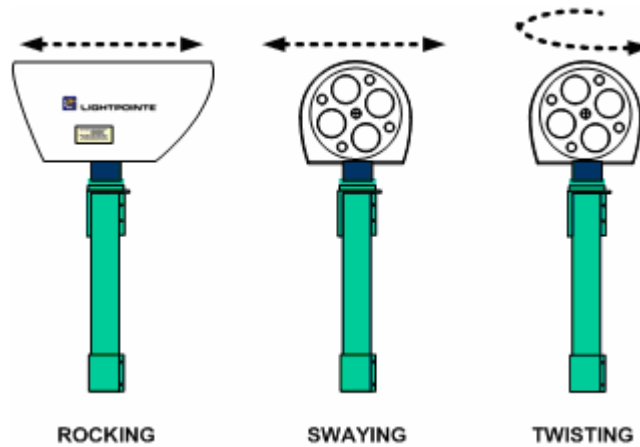

**Figure 2-13: Three Types of Mount Movement**

A simple test can be used to verify if you have a solid mount. The test simulates 100 mph wind and 1.5 mr or less of deflection. The universal LightPointe mount is engineered to withstand winds of 140 mph.

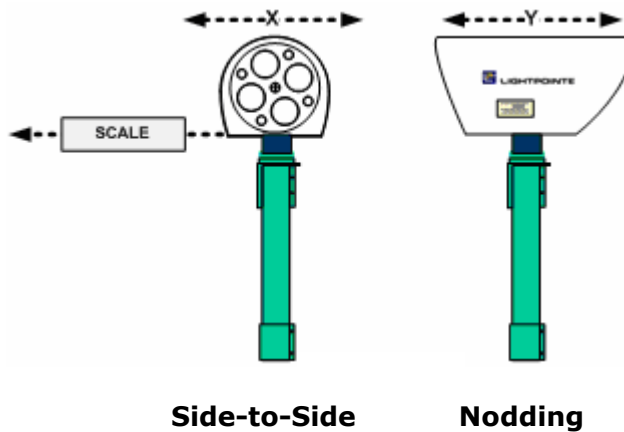

**Figure 2-14: Mount Stability Tests**

### **2.10.1. Mount Verification Test**

- Step 1**    Attach a fish weight scale to the head plate (Gimbaled Mount) as shown in Figure 2-14.
  
- Step 2**    Apply a force of 55 pounds (25 Kg) to the mount in the side-to-side direction. Observe the received power LED indicators to see if the signal level drops.
  
- Step 3**    Apply a force of 25 pounds (12 Kg) to the link head in the “nodding” direction. Observe the received power LED indicators. If the force can be applied without losing more than two bars of power at either link head your mount is solid and should give good service.

### **2.10.2. Network Switch Setup**

The following steps must be followed to setup the network switch.

- Step 1**    If switch is to be rack mounted, attach switch mounting hardware using screws provided.
  
- Step 2**    Connect power cord to back of switch and plug cord into a power outlet.

### 2.10.3. RF Equipment Setup

The following steps must be followed to setup the radio and antenna equipment.

**Step 1** Attach mounting kit to antenna housing.

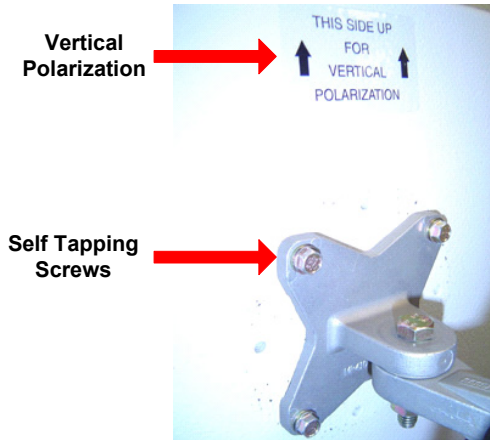

- Pre-assemble the antenna mounting kit using hardware provided.
- Make sure antenna polarity is correct before attaching the mounting kit.
- Attach mounting kit to back of RF antenna using self-tapping screws provided.

**Step 2** Attach antenna to mounting post.



- Place antenna on mounting post below the linkhead.
- Tighten corresponding bolts to secure (depending on post diameter).

**Step 3** Connect Ethernet cable.

- ❑ To ensure a weatherproof seal, place the CAT-5 cable wiring through the weatherproof gland before crimping connectors.
- ❑ Crimp on RJ45 connectors.
- ❑ Plug RJ-45 connector into the antenna bottom.



- ❑ Tighten gland onto antenna bottom.

**Note:** The combined length of the two CAT-5 cables must not exceed 200 feet.

**Step 4** Connect Power-Over-Ethernet Injector

- ❑ At indoor location, connect CAT-5 cable from antenna to POE injector.
- ❑ Use another straight CAT-5 cable to connect from the POE injector to the switch.
- ❑ Plug a power adapter into the POE injector and plug power cord into a power outlet.

## 2.11. System Alignment

### 2.11.1. Automatic Beam Tracking and Power Control

The FlightStrata 100 XA systems have an automatic beam tracking and Automatic Power Control system which adjusts the alignment and receive power levels of the linkheads during day to day operation.

However, the tracker mechanism will perform best when the mounts are solid and the initial starting position is perfectly centered in the Range of Motion of the tracker. This is why it is important to have the tracker OFF when performing the initial alignment.

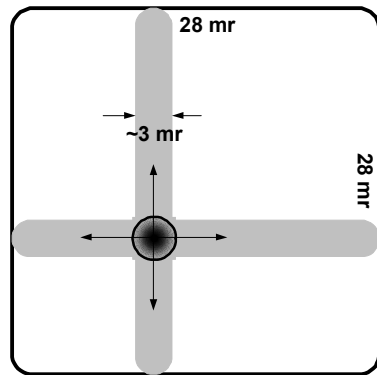

**Figure 2-15: Automatic Tracking**

The tracker will move within the Field of Regard in first in the X and then in the Y direction over a total of 28 mr of angular deflection. The Field of View/Divergence remains the same at all times.

The Tracker will search for the highest receive power within the Field of Regard. It constantly searches to see if there is a higher power level and moves all four beams at the same time.

The Tracker samples on a random time interval varying from 15 to 25 seconds. This is much faster than any diurnal affects which typically occur over hours. The random timing of the sample is done to eliminate the chance that both linkheads would begin tracking at the exact same time and thus never "find" each other.

Automatic Power Control samples every two seconds and adjusts the Receiver power level for optimal performance. This is much faster than a fog or fading event ever occurs. The action is dampened (statistically) to prevent flapping or constant adjustment problems when the power is changing rapidly due to blowing fog or rain.

When the FlightStrata 100 XA is first powered on, Tracker/APC should be off. The system will perform self-diagnostics at power on. During this sequence (up to a minute in length) the motors will make different noises because the system is testing the edges of the Field of Regard. When the motors hit the edge of travel, you will hear the motors running. The main purpose of this sequence is to center the tracker in preparation for the manual alignment process. When the self-diagnostics are complete you should proceed to linkhead alignment with Tracker OFF.

After manual alignment, you may turn on tracker/AGC and FlightStrata 100 XA will automatically optimize both alignment and received power level.

- ❑ APC starts first and will quickly reduce power to 7 or 8 bars. This should take only a few seconds - the power levels will fluctuate as the tracker activates
- ❑ Tracker then begins to find perfect alignment by hunting back and forth and up and down. This entire process may take up to five minutes

The tracking switch controls both the Tracker and Automatic Power Control functions. APC will not operate if Tracker is working. Tracker will not operate while APC is adjusting power. You will never see Tracker and APC fighting each other in any way.

### 2.11.2. Linkhead Alignment

The following steps must be followed to properly align the system. A single person can perform linkhead alignment. However, it is easier with two people. The only tool required to perform coarse system alignment is the Allen wrench (metric #6) that is provided with the system (stored on the back of the linkhead).

**Note:** When you are finished aligning the system, always return the Allen wrench to its holder.

Perform the following steps at both linkheads:

- Step 1** Open the back panel door.
- Step 2** Remove the lens cover from the linkhead telescope.
- Step 3** Loosen the Pan and Tilt bolts to allow for coarse alignment
  - ❑ The Pan and Tilt assembly has two sets of bolts – Coarse alignment and Fine Alignment bolts.
  - ❑ There are also two fine alignment screws that are used as a final adjustment. The fine alignment screws make it easy to get perfect alignment of the systems by fine tuning the pointing direction.

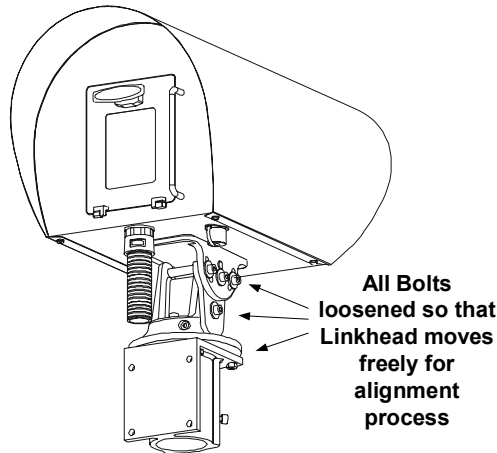

- Step 4** Ensure that the "**Tracking**" switch is in the "**Off**" position (not depressed), and then turn the linkhead power switch to the "**On**" (up or "**1**") position.
  - ❑ If the linkhead is properly connected to the power supply, the linkhead will move through its initial start-up sequence self-test process, which will cause a number of indicator lights on the rear panel to illuminate

- ❑ Once the self-test is completed, the linkhead will initiate a motor power test and orientation sequence of the tracker, during which time the Receiving Level Bars on the rear panel of the linkhead will alternately flash on and off
- ❑ When the Receiving Level Bars stop flashing, the self-test and tracker orientation process is complete. This total activity could take 2 minutes but generally will be completed in about 20 seconds

Please refer to Figure 2-16 in Section 2.12 of this manual for assistance in identifying the switches and indicator lights on the rear panel of the linkhead.

Disconnect the network data ethernet connectors from the linkheads.

**Note:** When the network data signal cable is unplugged from the linkhead, the linkhead automatically generates an idle tone. The LOS LED will also be illuminated solid red indicating an idle tone is being transmitted



**Caution:** Before aiming the telescopes, review the safety section of this manual and the following table of safe minimum telescope operating distances.

Linkhead	Telescope Safety Distance
FlightStrata 100 XA	0 m (0 ft)

**Step 5**

Remove the lens cover and center the telescope crosshairs of each linkhead on the opposite linkhead face plate.

**Telescope**



- ❑ The telescope is integrated into the **FlightStrata 100 XA** enclosure
- ❑ The telescope is not a true indicator of alignment
- ❑ When the system is powered on, always rely on the power level indicator bars to refine the alignment of the system
- ❑ If the initial coarse alignment of the system with the telescope is successful, one or more Receiving Level Bars should be illuminated

**Note:** From this step forward, alignment is usually accomplished more quickly if both linkheads are powered on and the remaining steps are worked alternately between the two linkheads. It is important that only one linkhead be moved at a time during the alignment process, otherwise it may be more difficult to align the system and optimal alignment may not be achieved.

**Step 6** Using gentle pressure to pan the linkhead assembly and the tilt adjustor on the pan and tilt assembly to tilt the linkhead, move the linkhead in the direction(s) necessary to increase the number of Receiving Level Bars illuminated on the back panel.

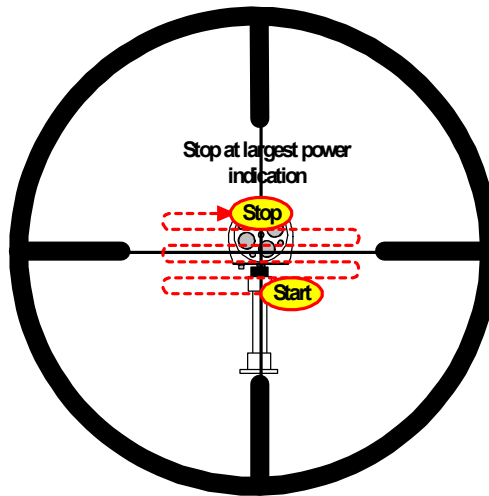

- A minimum of 2 bars is needed
- 5 to 9 bars are desirable and achievable, depending on the distance between the linkheads

**Step 7** Repeat Steps 1-6 at the opposite linkhead if these steps were not performed alternately between the two linkheads.

- Adjust both linkheads until they have approximately the same maximum receive power levels

**Step 8** On both linkheads, tighten the six silver coarse alignment bolts

- ❑ There are four bolts around the base and two bolts on the side of the top table section of the Pan and Tilt assembly.
- ❑ Tighten the six bolts as tight as you can using the hex wrench supplied

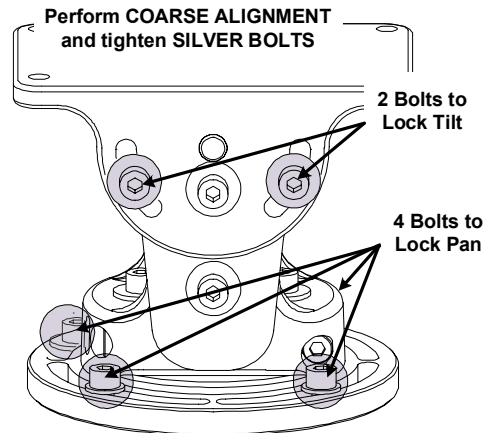

**Step 9** Tighten the four Gold Fine Alignment Bolts

- ❑ When the fine alignment is complete, tighten the four Gold colored Fine Alignment bolts.

There are two bolts on the base and two bolts on the side of the top table section of the Pan and Tilt assembly.

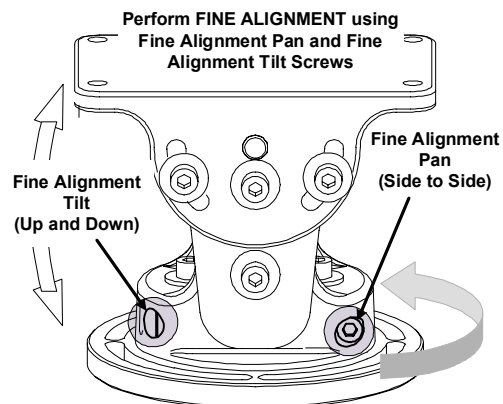

- ❑ It is usually best to start with the aim a little low adjust back and forth in one complete sweep. Then turn the tilt adjuster screw 1/8 turn to raise the linkhead angle and repeat the back and forth movement. Stop when you have reached the highest reading you can obtain by panning back and forth.
- ❑ Now proceed to find the best tilt angle using the rear pan adjuster screw to tune the receive level up and down to find peak power.
- ❑ Move only one linkhead at a time.

**Note:** Overload condition may occur on shorter shots. This is normal. It is a sign that you have good alignment and will be corrected when the Power Control is engaged.

**Step 10** Tighten the four gold fine alignment bolts. There are two bolts on the base and two bolts on the side of the top table section of the Pan and Tilt assembly.

- ❑ When the fine alignment is complete, tighten the four Gold colored Fine Alignment bolts.

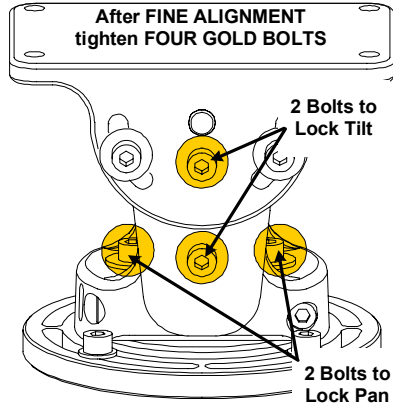

**Step 11** Reconnect both network data cables to the linkheads.

**Step 12** Set the **Tracker** switch to the "On" position. Note that this also engages the Automatic Gain Control (AGC) feature.

- ❑ The AGC adjusts for receive power to minimize the potential impacts of sunlight and scintillation
- ❑ The receive level bars will drop to between 6 and 8 bars if 8, 9 or 10 bars had been previously illuminated. This does NOT indicate any system performance issues
- ❑ As the tracking and AGC features are exercised, the number of receive level bars will periodically fluctuate. This is a routine part of the alignment process and is not an indication of system performance issues
- ❑ Initial positioning may take up to five minutes. this is normal.

**Note:** The use of the tracking and AGC feature is optional, but it is strongly recommended that this feature be employed continuously to optimize system performance.

The alignment procedures are now completed.

---

### 2.11.3. Alignment Troubleshooting Tips

The following tips can be used to troubleshoot alignment problems.

- Tip 1** If you cannot get a signal, confirm that the linkhead is transmitting through Free Space with its lasers by checking that the power is On.
- ❑ The red Test switch LED on the back panel should remain illuminated through the alignment procedure.
- Tip 2** Keep watching the receive power level bar graph as you slowly move only one of the linkheads.
- ❑ At least three signal level bars will be quickly illuminated when you pass through the alignment range. Even a small flicker of power is an indication that you have alignment for a moment. Return to that position and make small movements.
- Tip 3** Before you leave, re-tighten all locking screws and reset the test switch to the Test off position – LED dark.
- ❑ After the linkheads are aligned it is important to switch both Test mode switches off. Network traffic will not pass through the system if either one of the linkheads is left in Test Mode.

### 2.11.4. RF Antenna Alignment

The following steps must be followed to properly align the RF system. A single person can perform antenna alignment. However, it is easier to perform the procedure with two people.

Perform the following steps at both antennas:

- Step 1** Ensure the radios have been properly pre-configured (Section 2.6.2).
- Step 2** Ensure the system is interconnected as shown in Figure 2-4. Double check switch port usage:
  - Port #22 – Linkhead Data (STP enabled)
  - Port #23 –Linkhead Management
  - Port #24 – RF Unit (STP Enabled)
  - Port #1 – Switches must be disconnected from the network while performing configuration procedures
- Step 3** Connect an ethernet cable between port 1 and the ethernet port on a PC.
- Step 4** Start up a Browser program on the PC.
  - The linkheads can be configured using a web browser such as Netscape® Navigator (version 6.2 and higher) or Microsoft® Internet Explorer (version 5.0 and higher)
- Step 5** To access the FlightManager XA window, at the browser URL address line enter the appropriate linkhead default IP address (see Table 2-1, Table 2-2 or Figure 2-4). The Main FlightManager XA window is displayed.

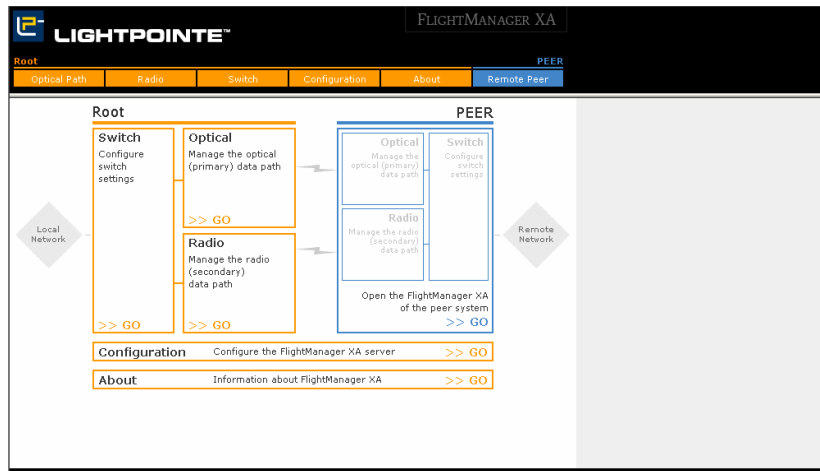

- Step 6** To open the Root Radio Web window from the Main FlightManager XA window, click on the Root Radio **GO** button. The Radio Main Status window is displayed.

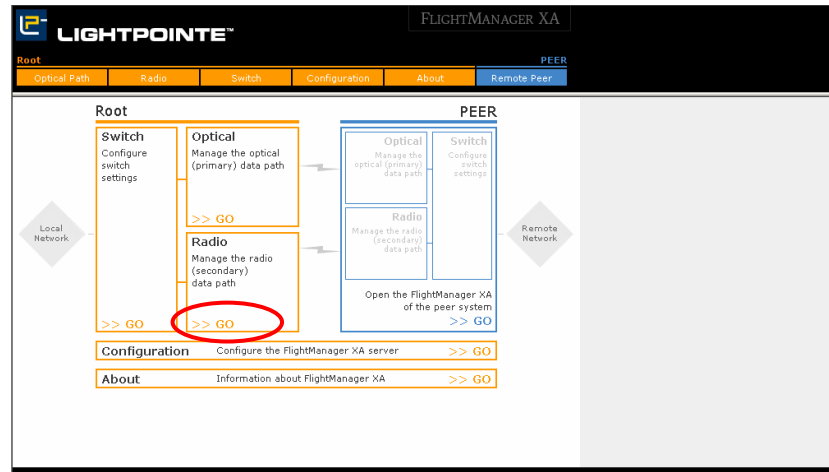

- Step 7** To check the peer radio port and receive and transmit data status, click on the lower MAC address. The Peer Radio Status window is displayed.

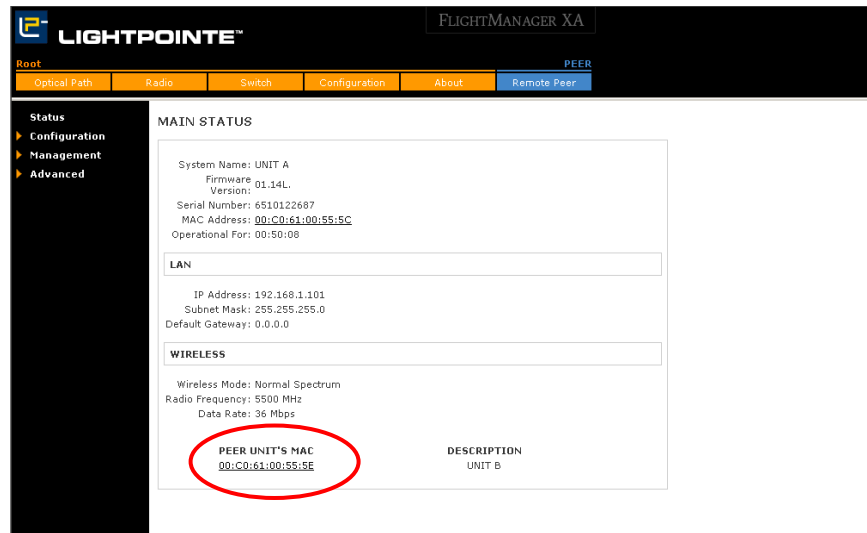

The radio configuration procedures performed at this point are identical to the procedures found on page 2-18, starting at Step 5.

**Note:** You must use the procedures in Section 2.6.2 if you decide to change the IP Addresses to a new Subnet.

- ❑ Click the Back button to return to the Main Status window.

**Step 8** Check the Receiver Signal Strength Indicator (RSSI) screen on each unit via a browser interface.

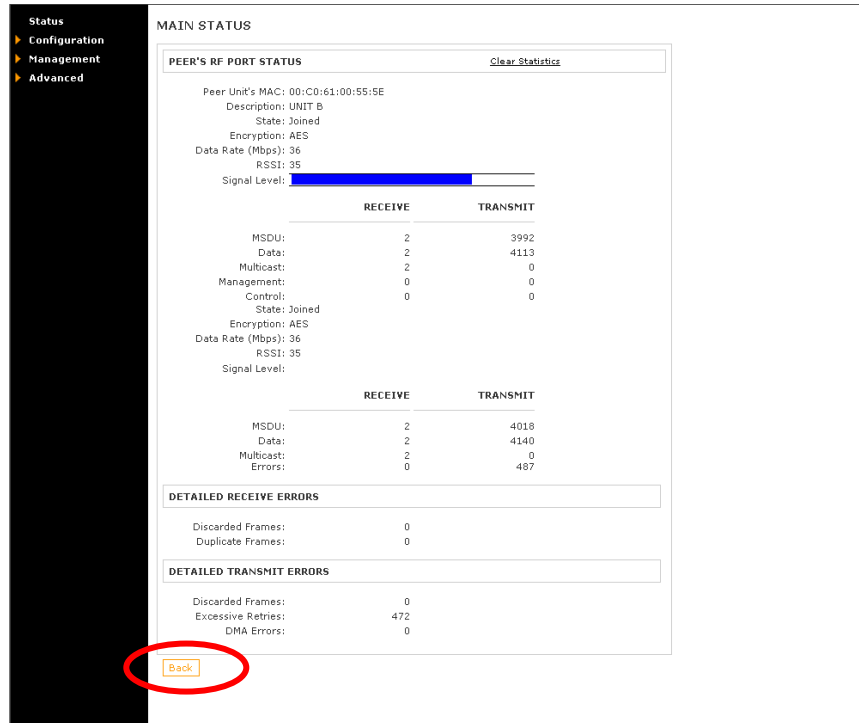

- RSSI is the receive signal strength from the other radio
- A level above 20 RSSI is desired
- A RSSI level over 40 may saturate the receive

**Step 9** Align the antenna.

- Adjust antenna to optimize RSSI value
- When making physical adjustments, it's always easier to move one radio at a time in small increments
- Click the Back button to return to the Main Status window.

**Step 10** To return to the FlightManager XA window, click on the LightPointe logo at the upper left corner of the window. The main FlightManager XA window is displayed.

**Step 11** To configure the Peer Radio, click on the Peer **GO** button. The Radio **GO** buttons on the left side of the Window can now be used to access the Peer radio.

**Note:** FlightManager XA only supports one connection at a time. Do not open FlightManager XA browser sessions from multiple computers.

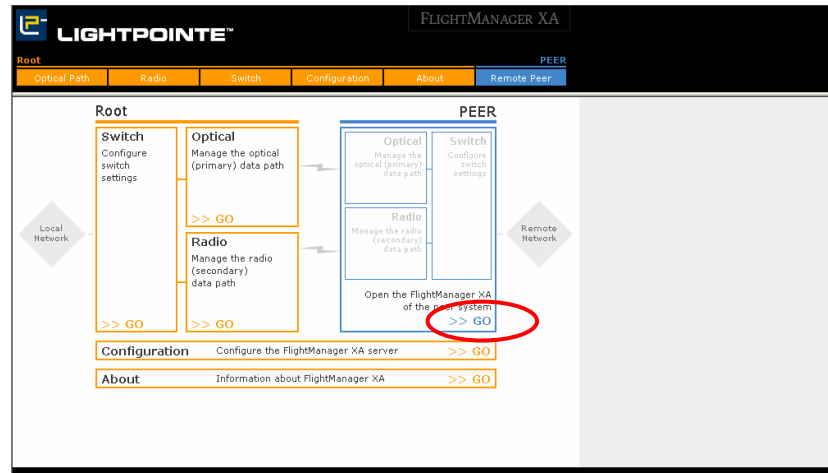

## 2.12. Verify System Operation

### 2.12.1. Verify Optical System

Figure 2-16 shows the displays, controls, and indicators on the back panel of the linkhead. Table 2-4 describes these components.

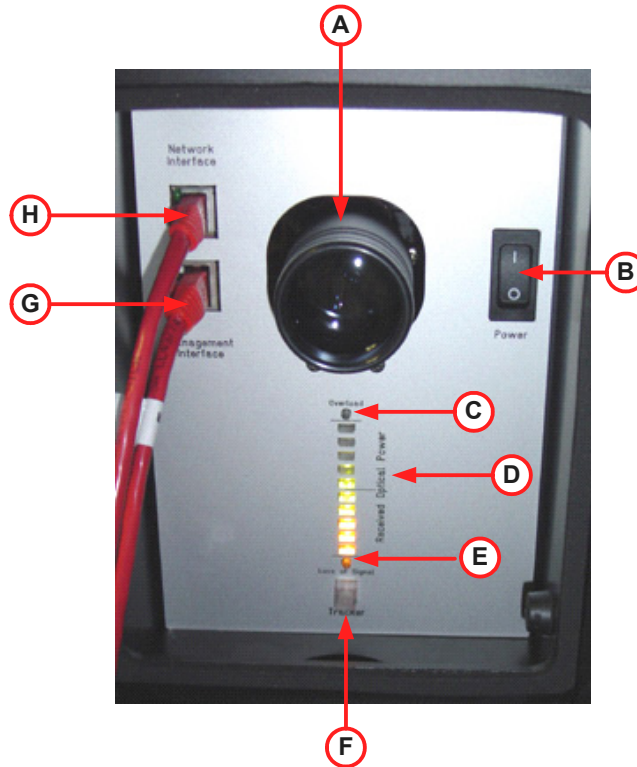

**Figure 2-16: Linkhead Back Panel**

**Table 2-4: Linkhead Back Panel Displays, Controls, and Indicators**

	<b>Back Panel Item</b>	<b>Description</b>
<b>A</b>	Telescope	Used for course alignment of linkheads
<b>B</b>	Power Switch	Main power switch
<b>C</b>	Receiver Overload LED	Red if the optical interface receiver is overloaded
<b>D</b>	Receive Level LED Bar graph	Displays receive signal strength
<b>E</b>	Loss of Signal LED	Red if the air interface receiver signal level is too low
<b>F</b>	Tracker Switch	Automatic Gain Control power switch
<b>G</b>	Management Interface Input/Output	Linkhead FlightManager XA management and configuration port
<b>H</b>	Network Data Input/Output	Ethernet port

Check for normal operation of the linkhead system by observing the LEDs and bar graph displays on the back panel of each linkhead. Check the following displays for unit power and receive power status:

**Table 2-5: Bar graph and LED Operational Checks**

<b>Back Panel</b>	<b>Description</b>
Receiver Overload LED	Not red
Loss of Signal LED	Not red
Bargraph	5 to 7 LEDs lit
Tracker Switch	Illuminated

Please contact your distributor or LightPointe Technical Support if one of the red LEDs is illuminated and if you cannot fix the problem by using the troubleshooting procedures in Section 5 of this manual.

System installation and alignment procedures are now completed. The system should be fully operational.

## 2.12.2. Verify System Operation using FlightManager XA

- Step 1** Ensure the system components are properly connected and have power applied.
- Step 2** From a computer on the network, use Microsoft Internet Explorer to access the follow address: <http://192.168.1.101>. The Radio Welcome window is displayed.
- Step 3** From the Root radio Main Status window, click on the lower MAC address. Observe the peer radio RSSI (Receiver Signal Strength Indicator) value.

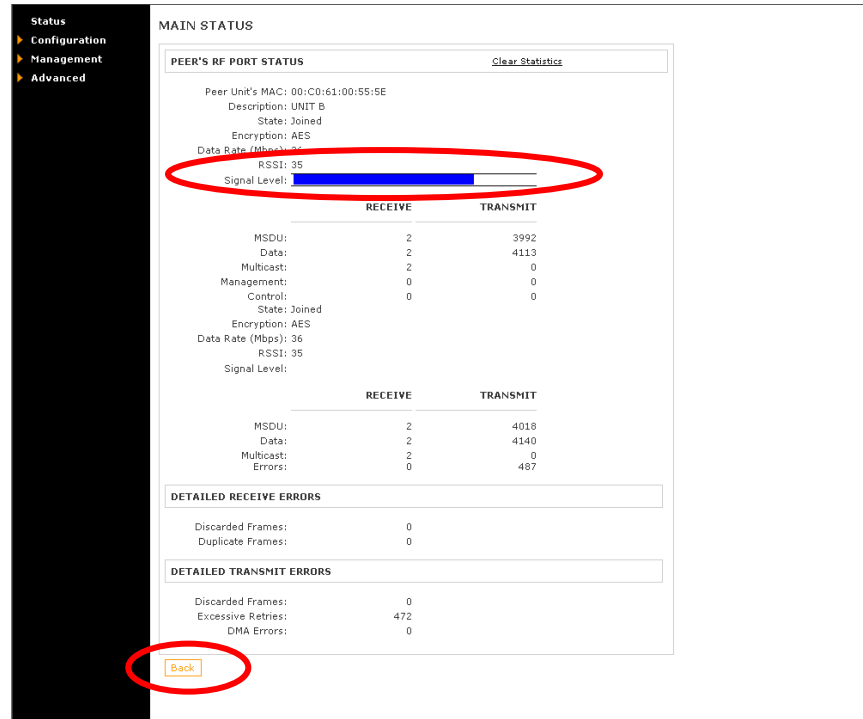

- RSSI is the receive signal strength from the other radio
- An level above 20 RSSI is desired
- An RSSI level over 40 may saturate the receiver

Click on the Back button to return to the Root radio Main Status screen. Check both radios.

**Step 4** Align the antenna.

- Adjust antenna to optimize RSSI value
- When making physical adjustments, it's always easier to move one radio at a time in small increments

## **3. Maintenance**

---

### **3.1. Scheduled Maintenance**

In general, FlightStrata 100 XA systems are maintenance free. Clean the heatable front window at least twice a year using a moist (water only) cloth. You may need to clean the window more often in dusty environments.

Alignment should be checked from time to time. Compare the number of signal strength bars with the original values if you are not sure that the system needs to be re-aligned.

Do not attempt to open the housing, as there are no user-serviceable parts inside.

#### **3.1.1. Field of View**

Periodically check the linkhead field of view for obstructions.



## 4. Troubleshooting and Diagnostics

---

This chapter covers the following main topics:

- ❑ Fault location
- ❑ Failure types
- ❑ Fault isolation and troubleshooting
- ❑ Additional troubleshooting methods
- ❑ Network monitoring
- ❑ Technical support
- ❑ Return material authorization (RMA) procedures

### 4.1. Fault Location

The linkheads can be thought of as pipes used to move data. No processing of data occurs within the linkheads. If the linkheads are aligned and data is moving between them (i.e. Test Mode), any system problem is usually caused by components outside the LightPointe system.

### 4.2. Failure Types

Three different kinds of failures can affect system performance:

- ❑ Failures caused by attached network components
- ❑ Failures caused by the environment
- ❑ FlightStrata 100 XA system failures

The troubleshooting flow chart (Section 4.3) should be used in the event of a LightPointe system failure. If a system failure occurs during initial installation, contact LightPointe Technical Support.

The most important error detection functions can be performed from the PC using the Management Port that allows you to pinpoint the failure precisely. More detailed troubleshooting can be done using FlightManager XA management interface window.



**Caution:** If a failure is found in the power supply unit, please remember that only authorized technical personnel may conduct checks of the power supply. In all cases, the system must be disconnected from the AC or DC power supply in advance of a service call.

### 4.2.1. Network Component Problems

There are a number of network-related problems that can cause the FlightStrata 100 XA system to malfunction.

**Table 4-1: Networking Equipment Problems**

<b>Network Problem</b>	<b>Effect on the XA System</b>
Bad network input signal	System failure, high BER, or low RSSI Link integrity LED is not illuminated on linkhead
Ethernet cable or connector damaged	No signal at the linkhead Ethernet port or radio Link integrity LED is not illuminated on linkhead No failure between optical and RF High number of errors
Cable length violation	Low signal strength at the linkhead or radio The maximum length of a CAT-5 UTP cable in an Ethernet segment must not exceed 100 meters (328 feet)
Cables reversed	Management Port and Network cables are reversed. Incorrect signal at the linkhead
Free-space optical signal weak	Link failure
RF signal weak	Link failure
Wrong switch port used	No communications, no fail over

### 4.2.2. Environmental Problems

There are a number of environmental problems that can cause the FlightStrata 100 XA systems to malfunction.

#### Optical Malfunctions

- ❑ Smoke emissions
- ❑ Fog, snow, or heavy rain
- ❑ Heat turbulence (shimmer)
- ❑ Tree (leaf) growth

#### RF Malfunctions

- ❑ Heavy rain emissions
- ❑ Tree (leaf) growth
- ❑ RF interference from nearby RF devices
- ❑ Fresnel zone violations

## RF System Fresnel Zone

The flat panel antenna has a narrow beam width (9°) to optimize performance and minimize interference.

- ❑ Obstacles encroaching more than 40% into the Fresnel zone may attenuate the received signal
- ❑ To avoid transmission loss, there should be no obstacle within the first 6/10ths of the RF Fresnel zone (known as 0.6 F1 clearance)

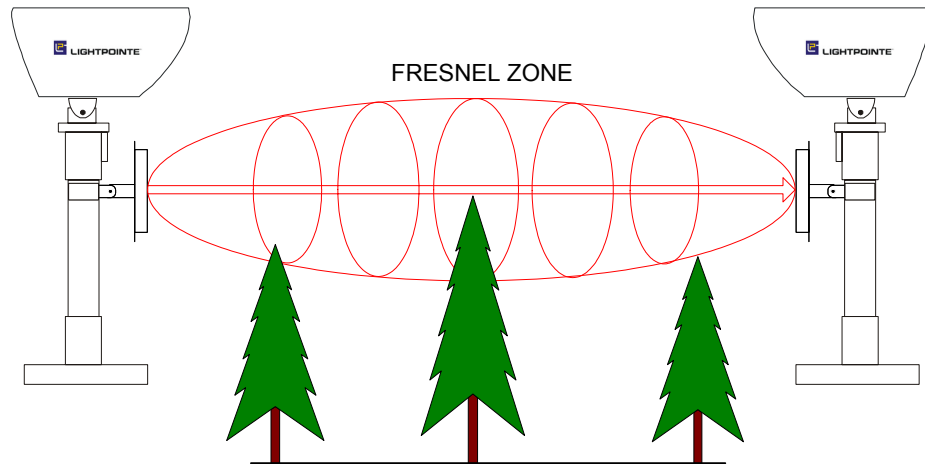

**Figure 4-1: RF Fresnel Zone**

The following formula is used to calculate the radius (in feet) of the Fresnel zone at a point in the path:

$$R = 7.21 \cdot \sqrt{\frac{d_1 d_2}{F(d_1 + d_2)}}$$

Where:

$R$  = Radius (in feet)

$d_1$  = distance from TX antenna (in miles)

$d_2$  = distance from RX antenna (in miles)

$F$  = Frequency (in GHz)

### 4.2.3. System Failures

An operational linkhead will display the following status on the back panel. If any of the indicators are different than those below, refer to Section 4.3, Fault Isolation Troubleshooting Trees.

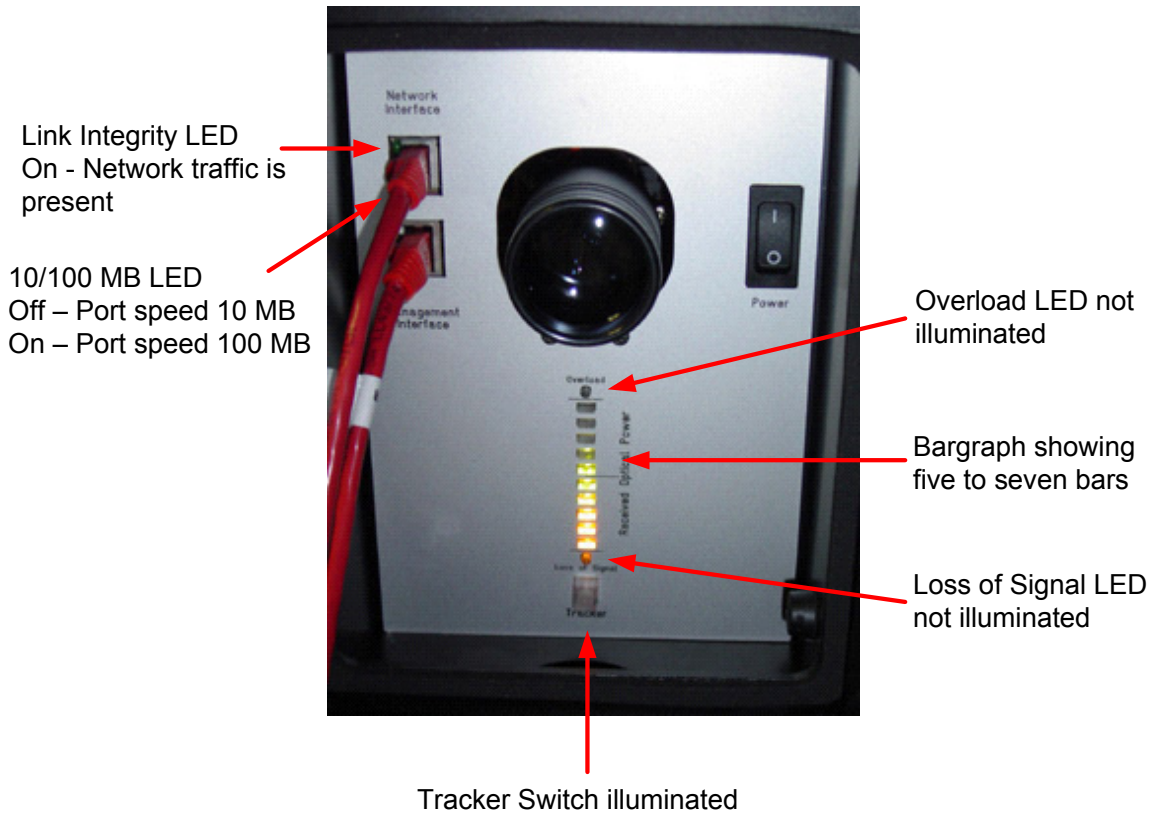

**Figure 4-2: Normal Back Panel Display**

### 4.3. Fault Isolation and Troubleshooting

The following flowcharts can be used to troubleshoot the system. Tasks marked with a gray circle can be accomplished using OMI diagnostic loop back tests.

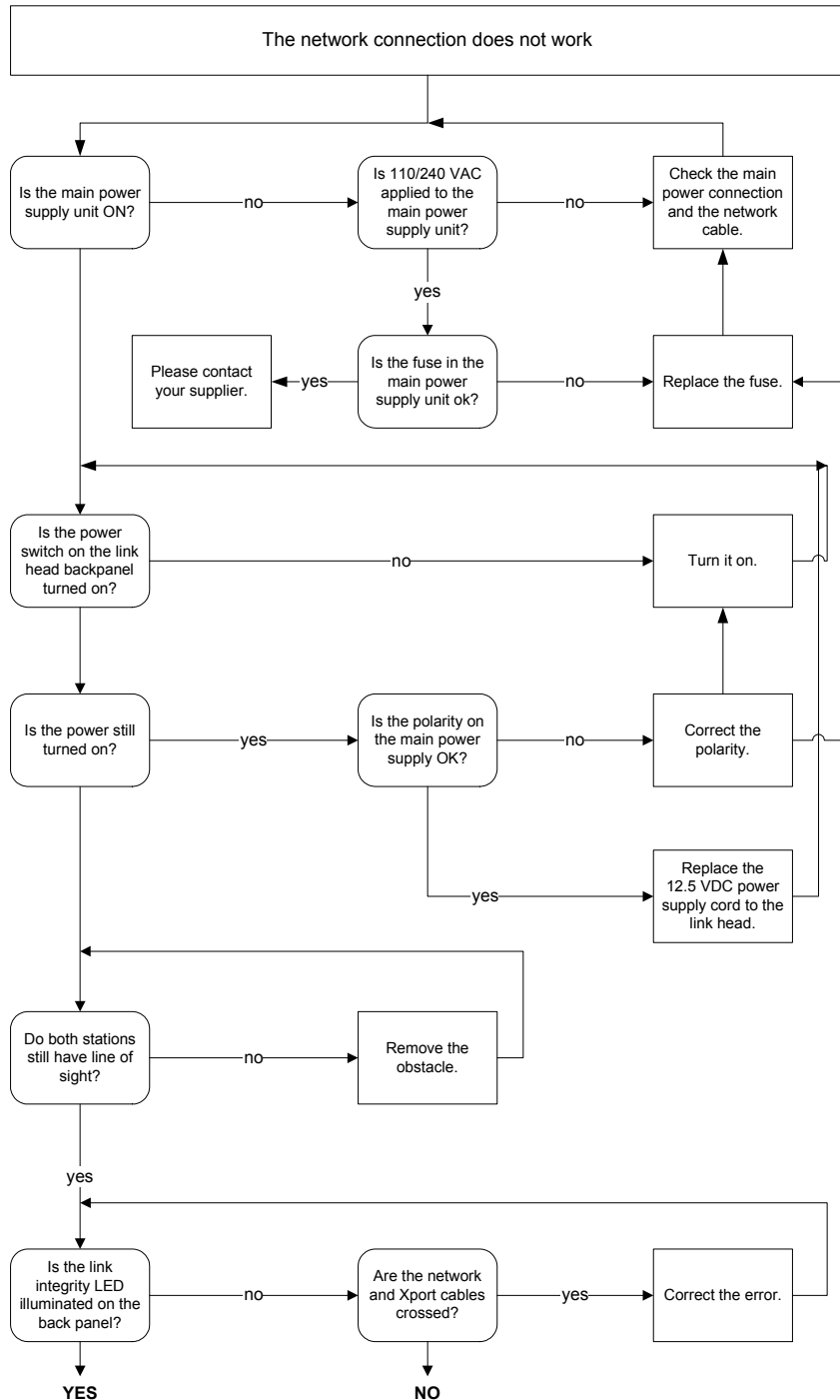
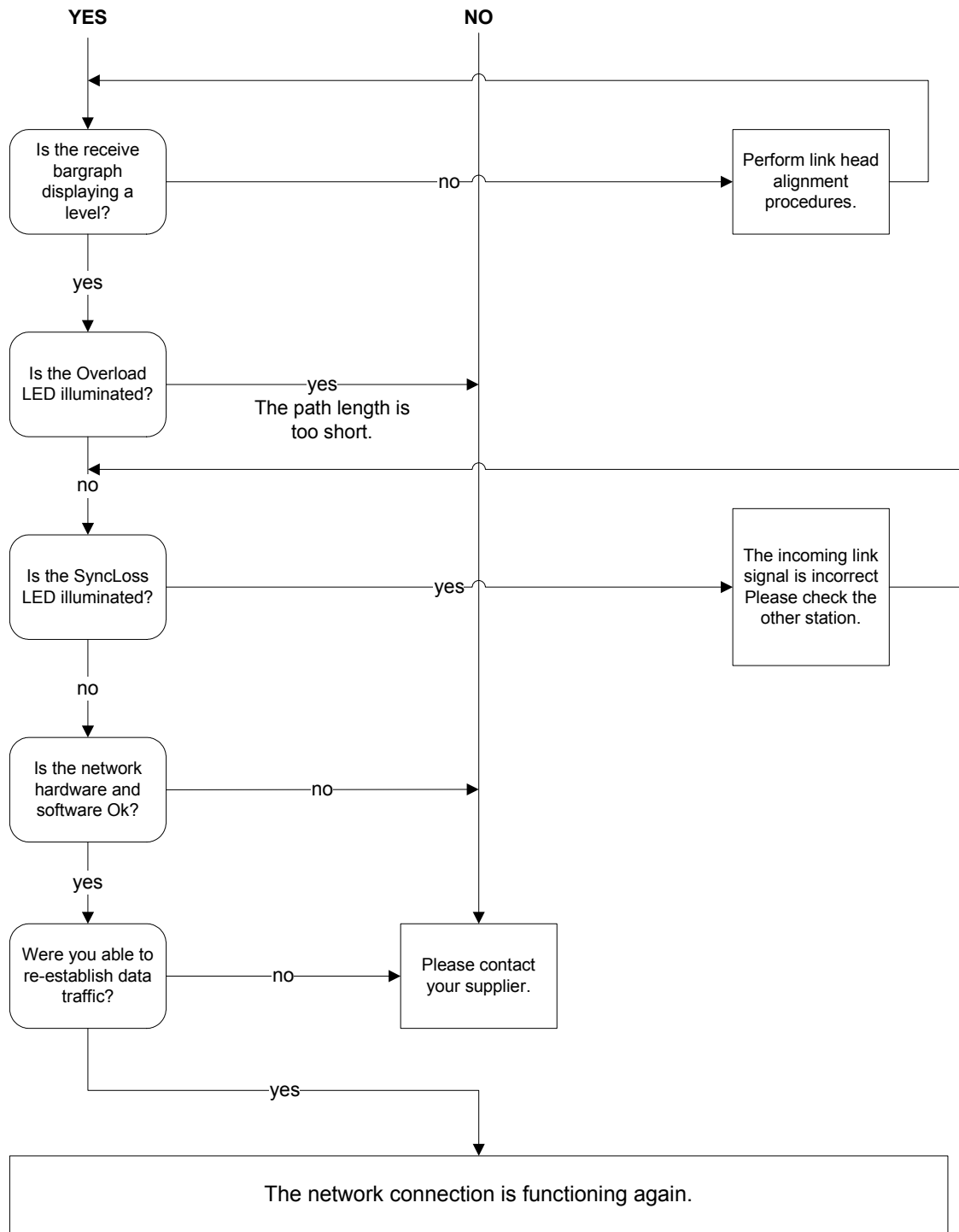

Figure 4-3: Troubleshooting Flowchart (Part 1)



**Figure 4-4: Troubleshooting Flowchart (Part 2)**

## 4.4. Additional Troubleshooting Methods

### 4.4.1. Ping Test to Check Configuration

You can use a laptop with Ethernet card to perform a ping test on the LightPointe XA Radios and Linkheads. Factory default LightPointe system component IP addresses are found in Table 2-1.

Customer requested IP addresses are found in Table 2-2. The following equipment is required to perform a ping test.

- ❑ Laptop with Ethernet card
- ❑ Ethernet cable with RJ45 connectors

The connections shown in Figure 4-5 are required to perform field diagnostic tests.

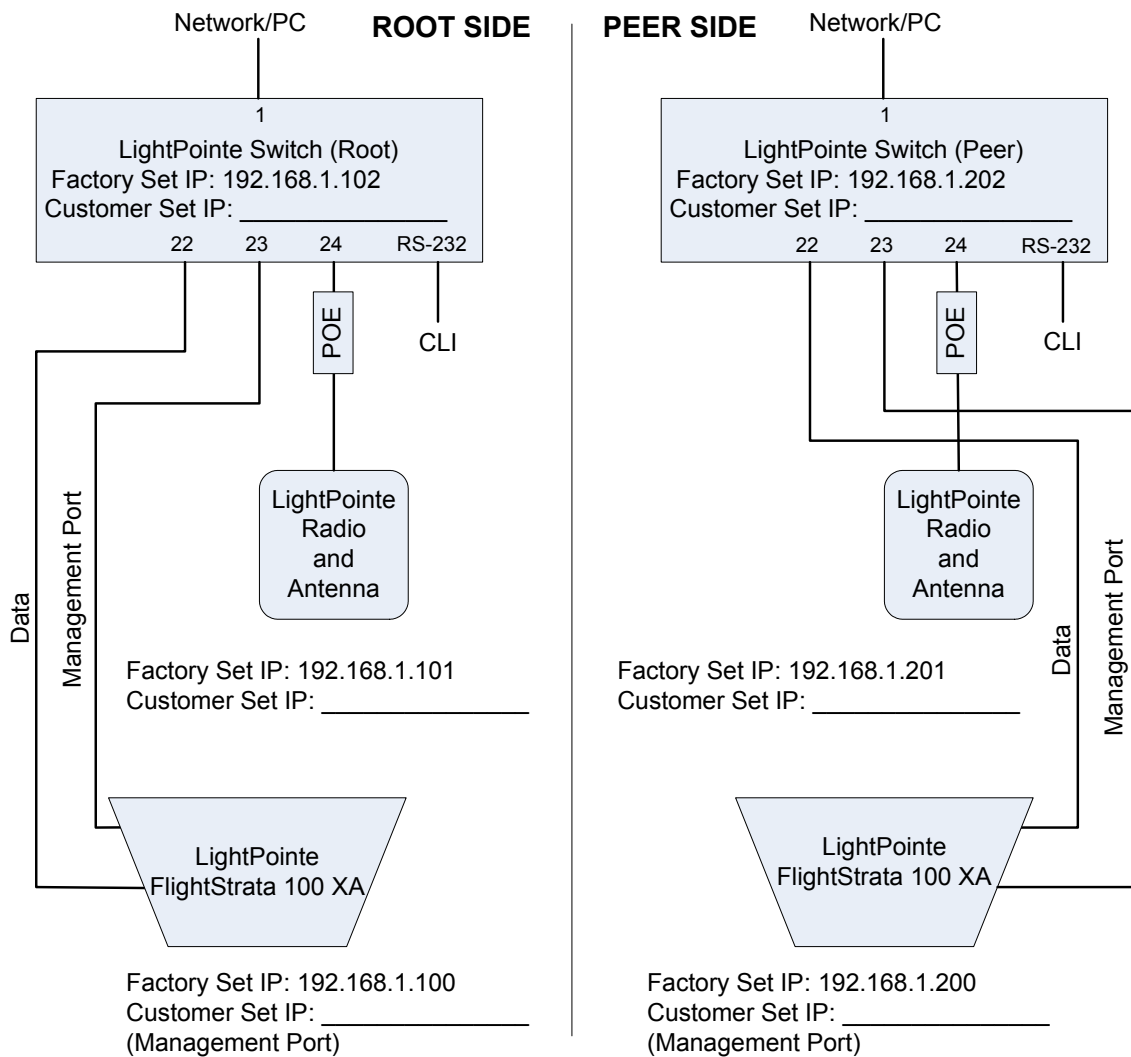

**Figure 4-5: Ping Test Setup**

**Step 1** Ensure the bench test system is connected as shown in Figure 2-4. Double check switch port usage:

- Port #22 – Linkhead Data (STP enabled)
- Port #23 – Linkhead Management Interface
- Port #24 – RF Unit (STP Enabled)
- Port #1 – PC connection

**Step 2** Power up all equipment.

**Step 3** Connect a PC to Port 1 of the Root or Peer switch.

**Step 4** Configure the PC IP Address and Subnet Mask.

- Use any IP address that won't conflict with current addresses (192.168.1.XXX)
- Use subnet mask 255 255 255 0

**Step 5** Click the **Start** button on the PC and select the **Programs** option.

**Step 6** Select the **MSDOS** prompt on the PC. The DOS window is displayed.

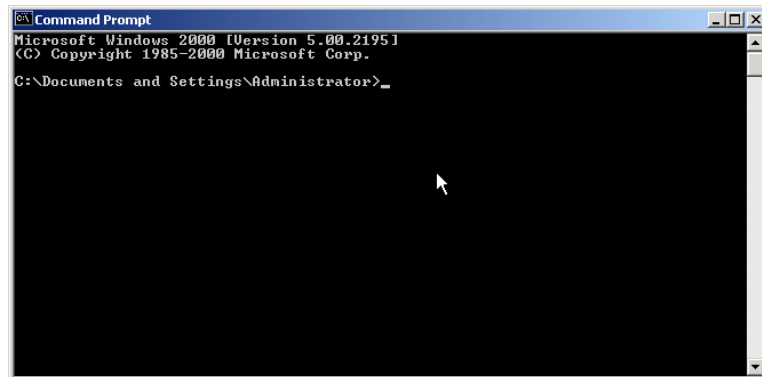

- Check the switch only if you are unable to communicate with the linkheads or RF units.

**Step 7** To ping from the Root laptop, type in the Peer IP address: **ping 192.168.1.XXX.**

To ping from the Peer laptop, type in the Root IP address: **ping 192.168.1.XXX.**

To stop the ping tests, type **<Ctrl> C** on each laptop.

- Step 8** A successful ping will display the following information on the PC screen.

```

C:\>Select Command Prompt
Microsoft Windows 2000 [Version 5.00.2195]
(C) Copyright 1985-1999 Microsoft Corp.

C:\>ping 168.101.1.10

Pinging 168.101.1.10 with 32 bytes of data:

Reply from 168.101.1.10: bytes=32 time<10ms TTL=128
Reply from 168.101.1.10: bytes=32 time<10ms TTL=128
Reply from 168.101.1.10: bytes=32 time<10ms TTL=128
Reply from 168.101.1.10: bytes=32 time<10ms TTL=128

Ping statistics for 168.101.1.10:
    Packets: Sent = 4, Received = 4, Lost = 0 (0% loss),
    Approximate round trip times in milli-seconds:
        Minimum = 0ms, Maximum = 0ms, Average = 0ms

C:\>_
    
```

- Step 9** If you block the FOV (field of view) of the linkhead and ping, the PC screen should read "unreachable parameters".
- Step 10** After completing ping tests, disconnect the PC cable from the switch and replace the network cable.

## 4.5. Network Monitoring

- Step 1** Connect a PC to Port 1. Ensure the system is connected as shown in Figure 2-4. Double check switch port usage:
- Port #22 – Linkhead Data (STP enabled)
  - Port #23 –Linkhead Management
  - Port #24 – RF Unit (STP Enabled)
  - Port #1 – Connected to a PC
- Step 2** Connect an ethernet cable between port 1 and the ethernet port on a PC.
- Step 3** Start up a Browser program on the PC.
- The system can be configured using a web browser such as Netscape® Navigator (version 6.2 and higher) or Microsoft® Internet Explorer (version 5.0 and higher)
- Step 4** Enter the IP address of the desired linkhead (refer to Section 0). The Main FlightManager XA window is displayed.

**Step 5** To open the Root Radio Web window from the Main FlightManager XA window, click on the Root Radio **GO** button. The Radio Main Status window is displayed.

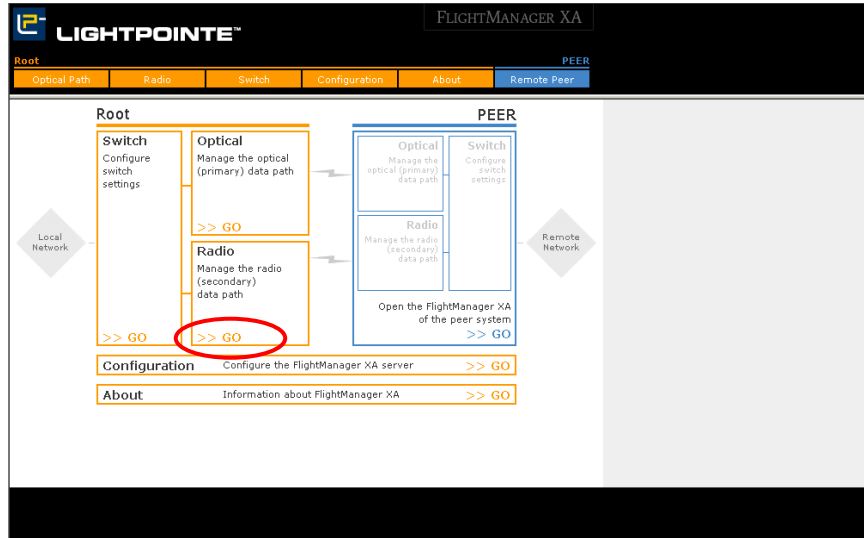

**Step 6** To check the Root radio receive and transmit data status, click on the upper MAC address. The Root Radio Status window is displayed.

❑ Click the Back button to return to the Main Status window.

The screenshot shows the Root Radio Status window. On the left, there is a navigation menu with 'Status', 'Configuration', 'Management', and 'Advanced'. The main content area is titled 'MAIN STATUS' and has a sub-tab 'RF PORT | ETHERNET PORT'. Below this, there is a section for 'RF PORT STATUS' with a 'Clear Statistics' link. The status information includes: Unit's MAC: 00:C0:61:00:55:5C, Description: Base, State: Up, and Encryption: AES. A table shows 'RECEIVE' and 'TRANSMIT' statistics for MSDU, Data, Multicast, Management, Control, and Errors. Below this are sections for 'DETAILED RECEIVE ERRORS' and 'DETAILED TRANSMIT ERRORS'. At the bottom, there is a 'Back' button circled in red.

	RECEIVE	TRANSMIT
MSDU:	2	3710
Data:	2	3368
Multicast:	2	0
Management:	0	0
Control:	0	0
Errors:	0	487

**Step 7** To check the peer radio port and receive and transmit data status, click on the lower MAC address. The Peer Radio Status window is displayed.

**MAIN STATUS**

**PEER'S RF PORT STATUS** Clear Statistics

Peer Unit's MAC: 00:C0:61:00:55:5E  
 Description: UNIT B  
 State: Joined  
 Encryption: AES  
 Data Rate (Mbps): 36  
 RSSI: 35  
 Signal Level:

	RECEIVE	TRANSMIT
MSDU:	2	3992
Data:	2	4113
Multicast:	2	0
Management:	0	0
Control:	0	0

State: Joined  
 Encryption: AES  
 Data Rate (Mbps): 36  
 RSSI: 35  
 Signal Level:

	RECEIVE	TRANSMIT
MSDU:	2	4018
Data:	2	4140
Multicast:	2	0
Errors:	0	487

**DETAILED RECEIVE ERRORS**

Discarded Frames: 0  
 Duplicate Frames: 0

**DETAILED TRANSMIT ERRORS**

Discarded Frames: 0  
 Excessive Retries: 472  
 DMA Errors: 0

Back

❑ Click the Back button to return to the Main Status window.

**Step 8** To return to the FlightManager XA window, click on the LightPointe logo at the upper left corner of the window. The main FlightManager XA window is displayed.

**Step 9** To verify Root switch operation, open the switch Web window from the Main FlightManager XA window by clicking on the Switch **GO** button. The Switch Web window is displayed.

**FLIGHTMANAGER XA**

Root PEER

Optical Path Radio Switch Configuration About Remote Peer

**Root**

Switch  
Configure switch settings

Optical  
Manage the optical (primary) data path

Radio  
Manage the radio (secondary) data path

**PEER**

Optical  
Manage the optical (primary) data path

Switch  
Configure switch settings

Radio  
Manage the radio (secondary) data path

Open the FlightManager XA of the peer system >> GO

Configuration Configure the FlightManager XA server >> GO

About Information about FlightManager XA >> GO

**Step 10** To open the Logon window, click on the spinning logo. The Switch Information window is displayed.

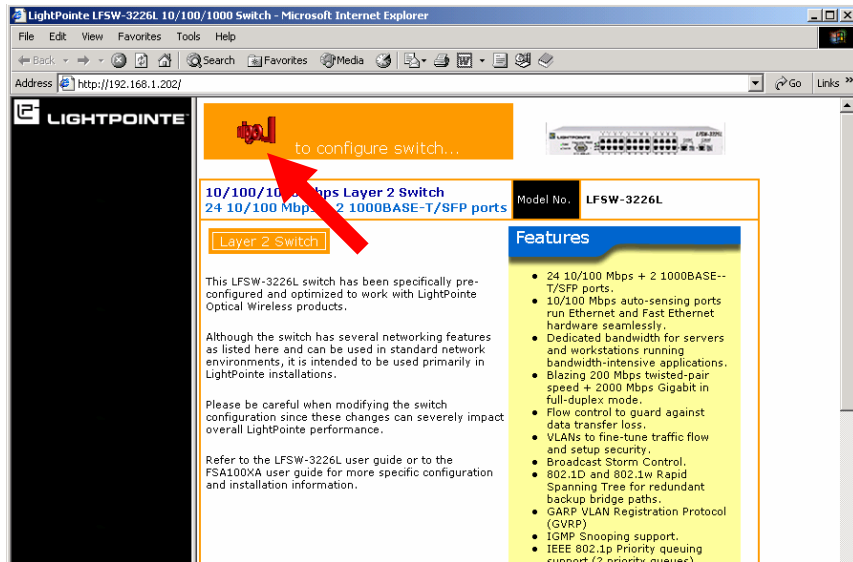

**Step 11** Click on **Basic Setup, Network Monitoring, Status, and Switch History** options. The Switch History window is displayed.

- View the Switch History window for any signs of errors.

**Step 12** Click on **Basic Setup, Network Monitoring, and Statistics** options. The Port Utilization window is displayed.

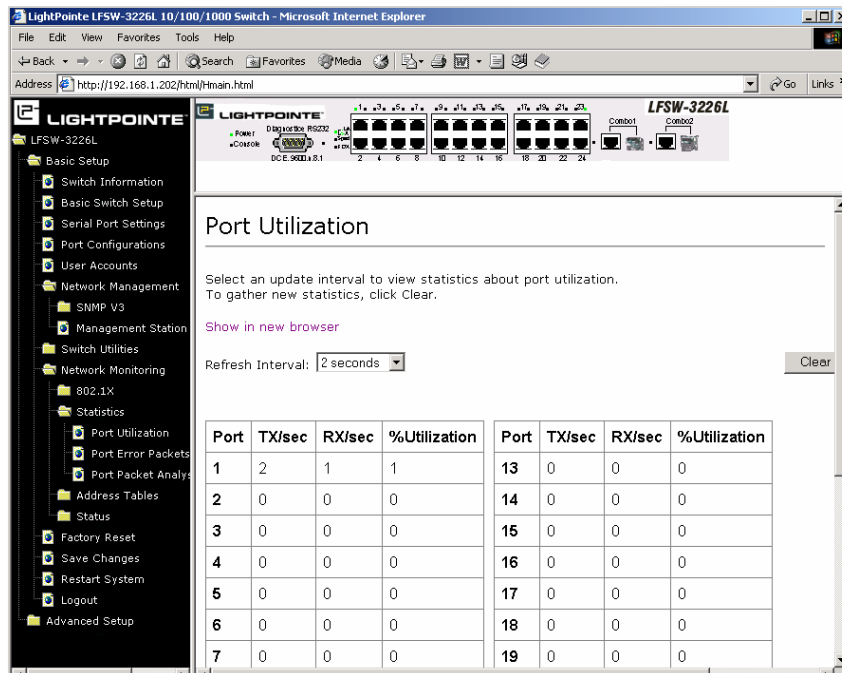

- View the Port Utilization window for any signs of errors.

**Step 13** Click on **Port Error Packets** option. The Port Error Packets window is displayed.

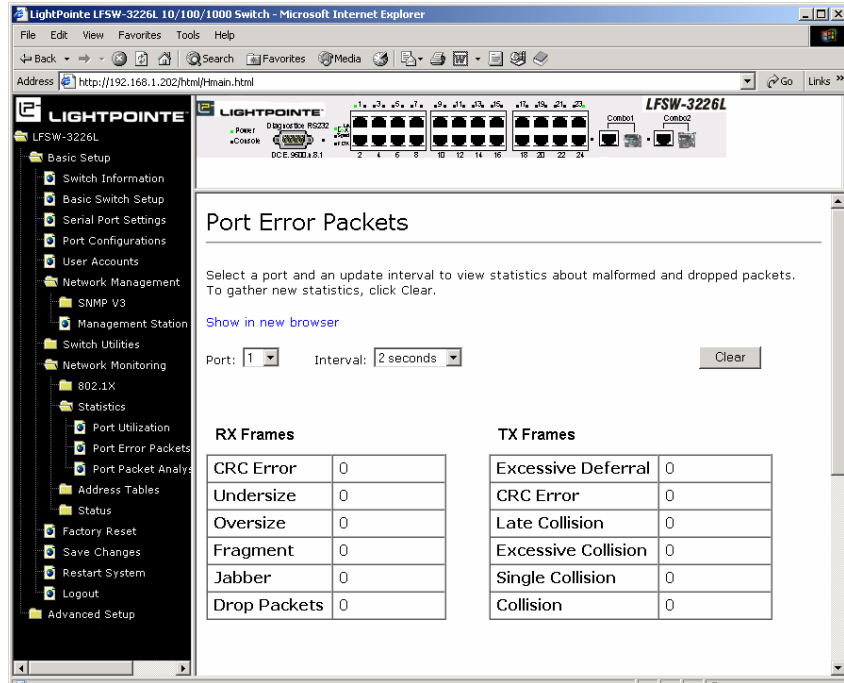

☐ View the Port Error Packets window for any signs of errors.

**Step 14** Click on **Port Packet Analysis** option. The Port Error Packets window is displayed.

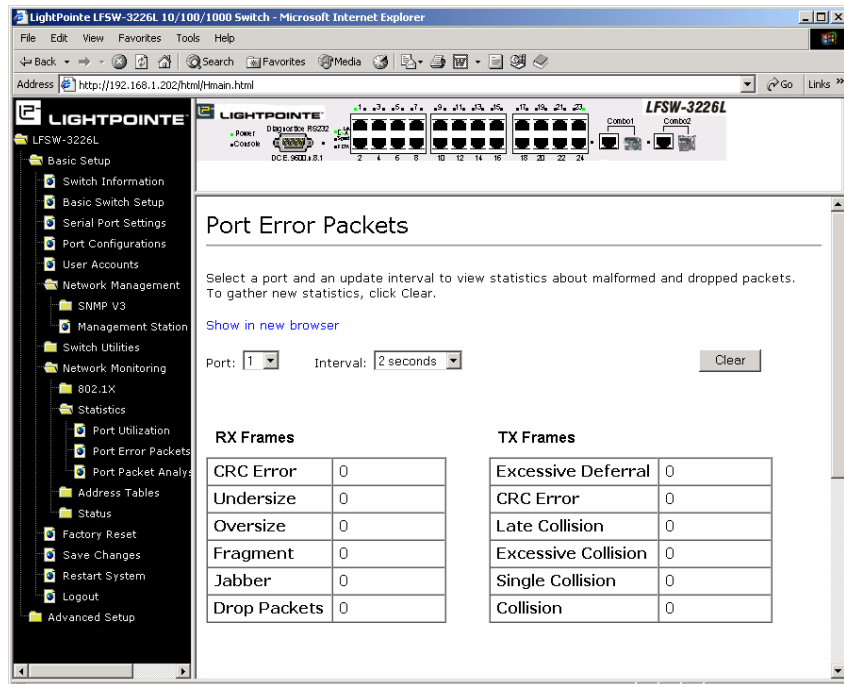

☐ View statistics about Port Packet Analysis window for any signs of errors.

- Step 15** To return to the FlightManager XA window, click on the LightPointe logo at the upper left corner of the window. The main FlightManager XA window is displayed.
- Step 16** To repeat the above steps on the Peer system, click on the Peer **GO** button. The Switch **GO** buttons on the left side of the window can now be used to access the Peer Switch.

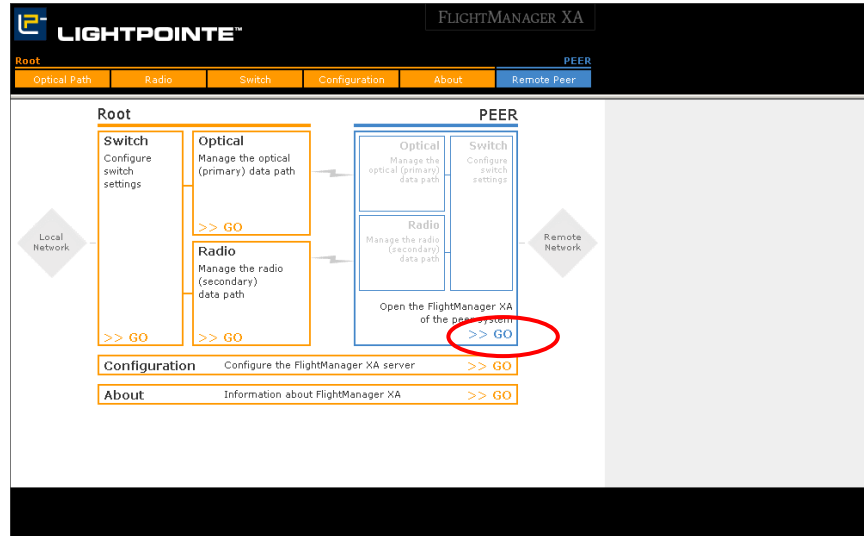

- Step 17** Exit the FlightManager XA program and disconnect the PC from the system. Reconnect the system (see Figure 2-4).

## 4.6. Technical Support

- Did you complete the steps in the Fault Isolation Troubleshooting Tree?

### 4.6.1. Checklist Before You Call Technical Support

- Be sure to fill out the following checklist before contacting LightPointe Technical Support.

General Information	Your Installation
<input type="checkbox"/> Application (Protocol)?	
<input type="checkbox"/> Distance?	
<input type="checkbox"/> How long has system been in operation?	
<b>How does the error show up?</b>	
<input type="checkbox"/> Temporary/permanent error?	
<input type="checkbox"/> Is error observed for the first time?	
<b>How was the weather when error showed up?</b>	
<input type="checkbox"/> What time of day?	
<input type="checkbox"/> Special weather conditions (fog, snowfall)	
<input type="checkbox"/> Outside temperature (moisture on entrance window)	
<b>Status of Back Panel LEDs</b>	
<input type="checkbox"/> Are all red LEDs off?	Yes/No
<input type="checkbox"/> How many bars does the bar graph indicator show?	
<input type="checkbox"/> Outside temperature (moisture on entrance window)	
<b>Status of Back Panel Indicators</b>	
<input type="checkbox"/> Connection to network	Yes/No
<input type="checkbox"/> Failure of endpoint equipment	Checked/Not Checked
<b>What type of system is installed?</b>	
<input type="checkbox"/> Model number	
<input type="checkbox"/> Serial number	
<input type="checkbox"/> Single mode or multimode	

**Note:** This form is available as a downloadable PDF file on our web site.

## **4.7. Return Material Authorization (RMA) Procedure**

Please contact LightPointe before returning any system components for repair or replacement.

RMA products include:

- Linkhead
- Standard power supply
- XA Switch
- XA Radio

## 5. Specifications

**Table 5-1: FlightStrata 100 XA System Specifications**

Product Information	Optical	Radio	Switch
Description	Outdoor Four-Beam Optics with Auto Tracking and Gain Control	Outdoor RF Bridge	Managed Layer 2 Switch
Receivers/Transmitters	Four Receivers Four Transmitters	Integrated Radio, High Gain Panel Antenna (22 dB), Lightning Protector	
Dimensions (WxHxL)	321 x 297.5 x 620 mm (12.6 x 11.7 x 24.4 in)	76.2 x 304.8 x 304.8 ((3 x 12 x 12 in)	441 x 66 x 388 mm (17.6 x 2.6 x 15.28 in)
Unit Weight	11.1 kg ((24.4 lbs)	9.09 kg (20 lbs)	6.0 kg (13.23 lbs)
Operating Voltage	90 to 240 V (50/60 Hz) or +48 V DC	Power-Over-Ethernet, DC Injector, Indoor (24 V, 1.5A)	100 to 240 V (50/60 Hz)
Operating Temperature	-25° to 60°C (-13° to 140°F)	-20° to 60°C (-4° to 140°F)	-0° to 40°C (32° to 1104°F)
Relative humidity	Up to 95% Non-Condensing	100% (IEC 529/IP67) Condensing	5% to 95% Non-Condensing
Power	40W	100mW (20 dBm)	
Mount	Gimbel	Two-Axis Mast Mounting Kit (included)	19-in Rack Mount Width
<b>Networking</b>			
Connectivity	Ethernet 10BaseT, 100BaseT	Ethernet 10BaseT, 100BaseT	Ethernet 10BaseT, 100BaseT, 1000BaseT, 100BaseFX
Interface	RJ-45 Copper Interface	RJ-45 Copper Interface	RJ-45 Copper Interface, SFP/Mini- GBIC
Data Rate	100 Mbps (Full Duplex)	72 Mbps (Half Duplex)	8.8 Gbps Switch Fabric
Operational Ranges	Up to 5 km (Line-of-Sight)	5 km (Near-Line-of-Sight)	
Configuration & Management	HTTP	HTTP, SNMP v1	HTTP, CLI/Console, SNMP v1, QoS, Load Balancing

**Note:** All FlightStrata 100 XA products are certified eye-safe in accordance with IEC/EN 60825-1 A2:2001 Class 1M standards.



## 6. Index

---

- A**  
Automatic Gain Control (AGC), 1-5
- C**  
coarse alignment, 2-37
- D**  
data rate, 2-1  
distance, 2-1
- E**  
environmental conditions, 2-2  
environmental problems, 4-2
- F**  
failure  
    power supply, 4-1  
failures, 4-1  
    attached network components, 4-1  
    environment, 4-1  
    system, 4-1  
fine alignment, 2-61  
fog, 4-2
- G**  
glasses  
    safety, iv  
GPS, 2-1
- H**  
head plate, 2-39  
heat, 2-2, 4-2  
Heavy Rain, 4-2  
hopping points, 1-1  
humidity, 2-2
- I**  
infrared light, 1-1
- L**  
laser safety, iv  
LED  
    loss of signal, 2-66  
    receive level, 2-66  
    receiver overload, 2-66  
lightning, 2-2  
line-of-sight, 1-1, 2-1  
Loss of Signal LED, 2-66
- M**  
Management Port, 4-1  
mount verification test procedure, 2-50  
Multi-Beam Tracking (MBAT), 1-5
- Multiple linkheads, 2-7
- N**  
network interface, 1-5  
network interface connections, 2-7  
network problems, 4-2  
non-penetrating roof mount, 2-2
- P**  
pan and tilt, 2-37, 2-39  
ping test, 4-7  
pole lengths, 2-42  
power, 2-7  
power supply, 2-38, 4-1  
Power Switch, 2-66  
problems  
    environmental, 4-2  
    network, 4-2
- R**  
rain, 4-2  
range finder, 2-1  
receive level, 2-66  
receive power level, 2-58, 2-61  
Receiver Overload LED, 2-66  
RF Fresnel Zone, 4-3  
RFI, 4-2  
roof edge, 2-2
- S**  
Safety considerations, 2-2  
Safety Labels, v, vi  
security, 2-2  
signal redundancy, 1-4  
smoke, 4-2  
snow, 4-2  
supplies, 2-5
- T**  
telescope, 2-39, 2-57  
temperature, 2-2  
template, 2-42  
test  
    ping, 4-7  
tools, 2-5  
tree, 4-2
- U**  
universal mount, 2-37
- W**  
wall mount, 2-37  
Warranty, ix

